

elina

PILATES

Live in balance





THE COMPANY

Our company has been dedicated to manufacturing Pilates equipment for 20 years, which has allowed us to gain extensive and in-depth experience and knowledge within the Pilates industry. We are a company committed to quality and innovation, which has led us to develop some of the most advanced and recognized Pilates equipment on the market.

Our products are designed to provide a superior Pilates experience for both beginner and advanced users. We offer a wide range of products, from classic Pilates machines to more innovative equipment that incorporates advanced technologies. All our products are designed in collaboration with international Pilates experts, ensuring their quality and effectiveness.

In our production processes, we ensure that only the highest-quality materials are used and that the strictest quality standards are applied at every stage of production. In addition, we are constantly evolving and developing new products, which allows us to remain at the forefront of the Pilates industry and continue improving the user experience. Our company also offers high-quality customer service, with a highly trained team committed to providing the best possible support to our clients. We care about meeting their needs and are always ready to help.

Finally, our products have received numerous praises and recognitions within the sector and are used and recommended by some of the most renowned Pilates professionals in the world. In addition, our company participates in major industry events. Thanks to our commitment to innovation and quality, we hold multiple patents and proprietary industrial designs that make our products truly unique.

INDEX

Elite Advanced Reformer	6-9	Wood Cadillac	92-93
Master Instructor Reformer	10-15	Classic Aluminum Cadillac	94-95
Mentor Reformer	16-21	Wall Board Onne	96-99
Elite Reformer	22-27	Wall Unit	100
Nubium Reformer	28-33	Wall Board	101
Nubium Black Edition Reformer	34-37	Ped & Pull	102
Lignum Reformer	38-41	Combo Chairs	104-107
Wood Reformer	42-45	Alma Chair	108-109
The Club Reformer	46-49	Combination Wunda/Electric Chair	110-111
Twin Reformer	50-51	Baby Chair	112-113
Aluminum Reformer HL 1-2-3-4	52-55	Classic Wunda Chair	114
Fold Reformer	58-59	Folding Mat with Handles	115
Vertical Reformer	60-61	Ladder Barrells	116-117
Domo Reformer	62-64	Arcs	118
Classic Aluminum Reformer 86"	65-69	Accesories	119
Classic Natural Wood Reformer 86"	70-75	Classic Accesories	120-122
Classic Walnut Wood Reformer 86"	76-81	Accesories	123-125
Corextreme	82-83	Small Equipment	126-141
Elite Cadillac Reformer	86-89	Comparison Chart	142-145
Cadillac Reformer	90-91		



ELITE ADVANCED REFORMER

ELN 100556

The Elite Advanced Reformer by Elina Pilates represents the evolution of our most recognized machine, designed to deliver maximum performance, versatility, and functionality in professional studios. It is crafted from high-quality maple wood and stainless steel metal components, ensuring durability, stability, and a premium user experience. One of the most outstanding features of the Elite 2.0 is its stackable design, ideal for optimizing space in studios. Its innovative design also incorporates improvements that enhance the training experience, such as the new infinite footbar, which slides along the entire length of the reformer, allowing quick adjustments and a greater variety of exercises.

FEATURES

- > Frame made of durable maple wood and designed for intensive professional use.
- > Sliding infinite footbar, allowing positioning along the entire length of the reformer for quick adjustments and greater exercise versatility.
- > Padded and non-slip footbar and standing platform.
- > Smooth and ultra-quiet carriage with eight polyurethane wheels and high-precision bearings.
- > High-quality upholstery, resistant to intensive and continuous use.
- > Automatic retractable rope system that allows the ropes to be stored underneath the carriage.
- > Carriage stopper system adjustable in 3 positions.
- > Complete set of six springs with a double-height spring bar to combine resistance levels according to the desired intensity
- > Three-position adjustable headrest.
- > Padded and adjustable shoulder rests, easy to place and remove.
- > Medium padded box, stable and comfortable for a variety of exercises.
- > Extra-wide removable jump board designed to facilitate proper foot placement.
- > Foot strap located in the well area, adjustable along the length of the machine.
- > Foot strap that can be positioned on both the inner and outer sides of the reformer.
- > Integrated wheels on the front legs to facilitate transport of the reformer.



Dimensions: 241 × 77 × 35 cm.

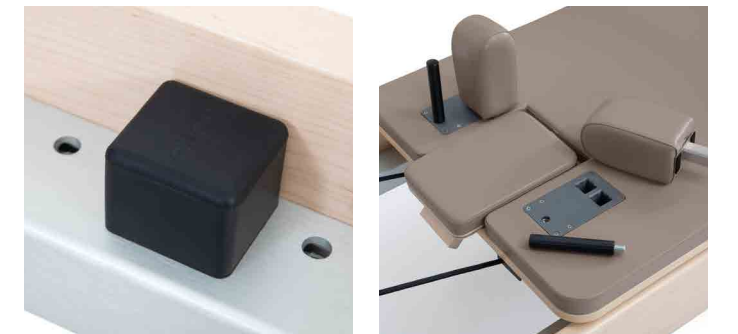



ELITE ADVANCED REFORMER WITH TOWER

ELN 300556

The Elite Advanced Reformer with Tower by Elina Pilates represents the evolution of our most recognized machine, designed to deliver maximum performance, versatility, and functionality in professional studios. It is crafted from high-quality maple wood and stainless steel metal components, ensuring durability, stability, and a premium user experience even in high-intensity training environments. Its innovative design incorporates improvements that expand training possibilities, such as the new infinite footbar, which slides along the entire length of the reformer, allowing quick adjustments and a greater variety of exercises and positions.

FEATURES

- > Frame made of maple wood, durable and designed for intensive professional use.
- > Sliding infinite footbar, allowing it to be positioned along the entire length of the reformer for quick adjustments and greater exercise versatility.
- > Integrated tower, expanding training possibilities by incorporating Cadillac-inspired exercises and vertical spring work.
- > Padded and non-slip footbar and standing platform for greater comfort and safety.
- > Smooth and ultra-quiet carriage with eight polyurethane wheels and high-precision bearings.
- > High-quality upholstery, resistant to intensive and continuous use.
- > Automatic retractable rope system that allows the ropes to be stored underneath the carriage.
- > Carriage stopper system adjustable in 3 positions
- > Complete set of six springs with a double-height spring bar to combine resistance levels according to the desired intensity.
- > Three-position adjustable headrest.
- > Padded and adjustable shoulder rests, easy to place and remove.
- > Medium padded box, stable and comfortable for a variety of exercises.
- > Extra-wide removable jump board designed to facilitate proper foot placement.
- > Foot strap located in the well area, adjustable along the length of the machine.
- > Foot strap that can be positioned on both the inner and outer sides of the reformer.
- > Integrated wheels on the front legs to facilitate transport of the reformer.

Dimensions: 241 × 77 × 35 cm.

Maximum height with tower: 202 cm.





MASTER INSTRUCTOR REFORMER

ELN 100146

The Master Instructor Reformer is an exceptional professional Pilates machine available in four versions designed to adapt to your needs. Each one is created to provide a superior training experience.

The Elina Pilates Master Instructor is a professional reformer made from American maple wood, available with two bed heights: 40 cm and 60 cm from the floor. The versatility of this reformer, which includes a mini tower, allows you to perform hundreds of exercises suitable for all levels, from beginners to advanced practitioners.

The Master Instructor not only includes everything needed for a complete workout, but also features innovative functionalities typical of a next-generation reformer.



MASTER INSTRUCTOR PHYSIO REFORMER

ELN 100176

FEATURES

- > Made with light-toned maple wood.
- > Waterproof varnish that protects the wood from wear and tear.
- > Mini Tower with Height and width adjustable pulleys.
- > Padded foot bar, with quick change system of seven positions "Quick release" with horizontal scrolling.
- > Ultra-quiet trolley.
- > Automatic rope collection retractable system.
- > Cushioning mechanism of the bed.
- > Adjustable padded shoulder straps that are easy to put on and take off.

Master Instructor: 242x83x40 cm.

Master Instructor Physio: 242x83x60 cm.



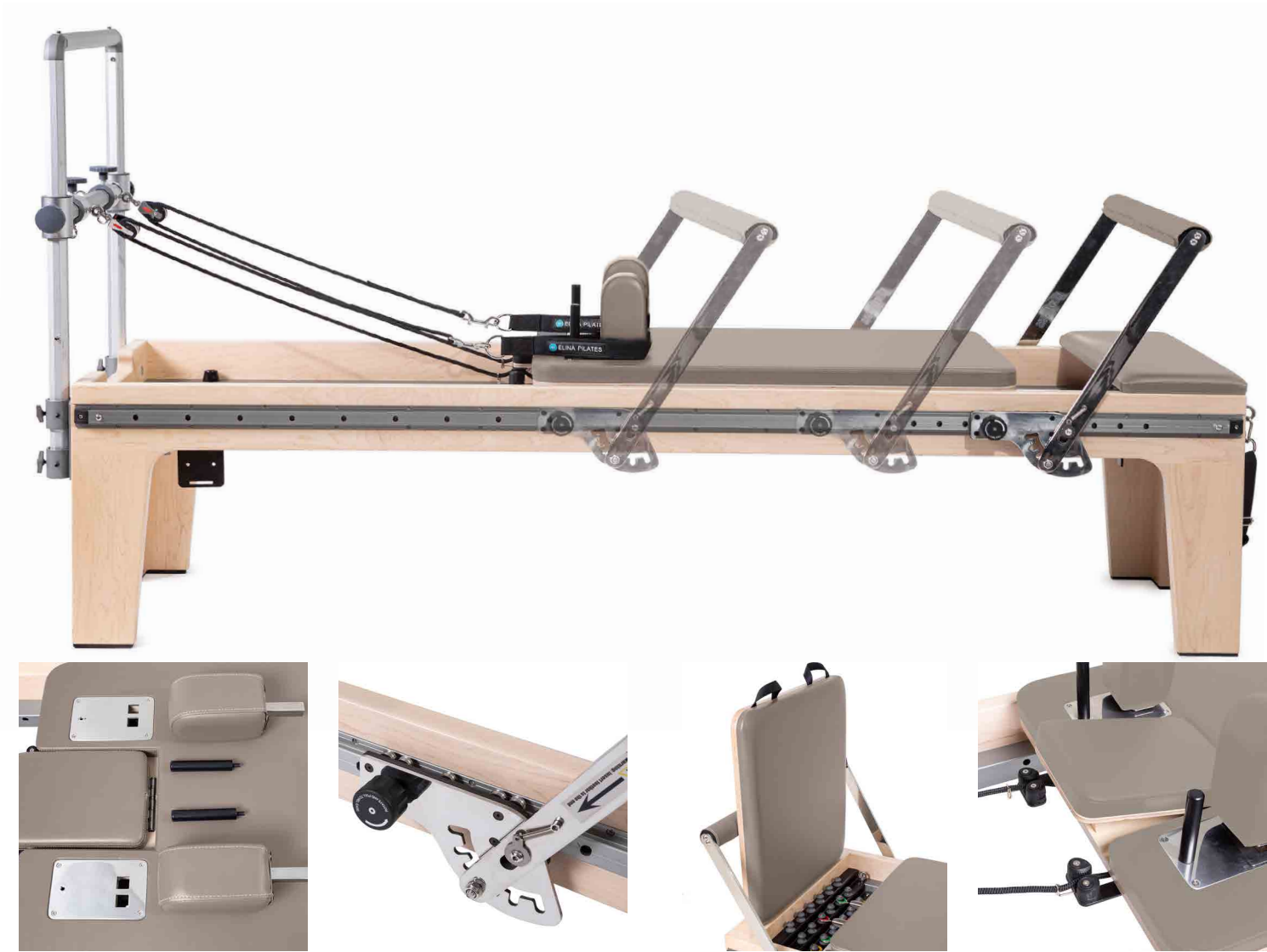

INCLUDES

- > Complete set of six high-precision springs.
- > Two low-resistance yellow springs.
- > Two medium-resistance green springs.
- > Two high-resistance red springs.
- > Extra wide padded box. It can be placed both parallel and perpendicular to the reformer.
- > Jumpboard.
- > Padded foot platform.
- > One set of hand handles and one set of double loop hand and foot handles.
- > A set of ropes.
- > Front foot strap: foot strap on the front of the reformer.
- > Adjustable foot strap.
- > Non-slip sheet.





MASTER INSTRUCTOR REFORMER WITH TOWER

ELN 100146

The Elina Pilates Master Instructor is a next-generation professional reformer featuring a carefully crafted contemporary design and high-quality finishes, making it an extremely attractive machine.

It includes everything needed for a complete workout, while also incorporating new functionalities beyond those of a traditional reformer. The versatility of this reformer allows for hundreds of exercises suitable for all levels, from beginner to advanced.



MASTER INSTRUCTOR PHYSIO REFORMER WITH TOWER

ELN 300176

FEATURES

- > Same features as the Reformer Master Instructor, adding the tower components:
- > Aluminum tower with numbered hexagonal profiles on both sides, with a quick system for changing the position of all its components.
- > A non-slip push bar.
- > Maple wood roll-down bar.
- > Set of 8 tower springs.
- > 1 set of simple foot grips.
- > Mat to cover the surface of the reformer.

Master Instructor: 242 x 83 x 40 cm.

Master Instructor Physio: 242 x 83 x 60 cm.

Height of Master Instructor Tower: 203 cm.

Height of Master Instructor Physio Tower: 223 cm.





MENTOR REFORMER

ELN 100406

Designed with both functionality and aesthetics in mind, it is a robust and compact machine.

The Elina Pilates Mentor is a highly functional professional reformer that includes everything you need for a complete workout, plus added exciting new features. The versatility of this reformer allows performing hundreds of exercises, adapted to all levels, from beginner to advanced.

FEATURES

- > Structure made of highly resistant anodized aluminum and steel feet.
- > Mini Tower with height and width adjustable pulleys.
- > Padded foot bar with “Quick release” change system with seven positions and horizontal scrolling.
- > Ultra-quiet trolley.
- > Automatic rope collection retractable system.
- > Cushioning mechanism of the bed.
- > Adjustable padded shoulder straps that are easy to put on and take off.

Dimensions: 259x75x40 cm.





INCLUDES

- > Complete set of six high-precision springs: two low-resistance yellow springs, two medium-resistance green springs and two high-resistance red springs.
- > Extra wide padded box. It can be placed both parallel and perpendicular to the reformer.
- > Jumpboard.
- > Padded foot platform.
- > One set of hand handles and one set of double-loop hand and foot handles.
- > A set of ropes.
- > Front foot strap: foot strap on the front of the reformer.
- > Adjustable foot strap.
- > Non-slip sheet.





MENTOR REFORMER WITH TOWER

ELN 300406

Designed with both functionality and aesthetics in mind, it is a robust and compact machine.

The Elina Pilates Mentor is a highly functional professional reformer that includes everything you need for a complete workout, plus added exciting new features. The versatility of this reformer allows performing hundreds of exercises, adapted to all levels, from beginner to advanced.



FEATURES

- > Same features as the Reformer Mentor, adding the tower components.
- > The tower is made of aluminum with hexagonal profiles that facilitate a firm grip and prevent slipping. With a quick system for changing the position of all its components.
- > Height adjustable pulleys.
- > Numbered and with adjustable hooks for the placement of springs, both in the front and in the rear, it allows exercises to be carried out on both sides of it.
- > Non-slip push bar, adjustable in height with safety strap.
- > Maple wood roll-down bar.
- > Springs: 2 light short (yellow), 2 medium short (green), 2 light long (yellow) and 2 medium long (green).
- > 1 set of simple foot grips.
- > Mat to cover the surface of the reformer.

Dimensions: 259x75x40 cm.

Height with tower: 190 cm.





FEATURES

- > Premium maple wood, stainless steel metal parts.
- > Silent and smooth slide system.
- > Adjustable shoulder pads in 4 positions. Adapted to any people.
- > Adjustable headrest in 3 positions.
- > 4 positions spring bar and 2 rows of prestressed anchor.
- > Springs: 2 light (yellow), 2 medium (green) y 2 strong (red).
- > A cotton handles: 1 set of double handles for hands and feet, 1 set of padded handles and 1 set of foot handle.
- > Pulley bars with quick height change and removable quick-release system.
- > 7-position quick-change footbar.
- > Adjustable and sliding fastening strap along the entire rail.
- > Stackable, wheels for easy transport.
- > Includes the jump board, box and standing platform.
- > 1 set of pulley ropes.
- > 1 adjustable foot strap.
- > Different colors of upholstery.

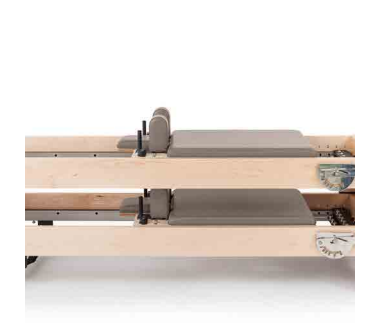
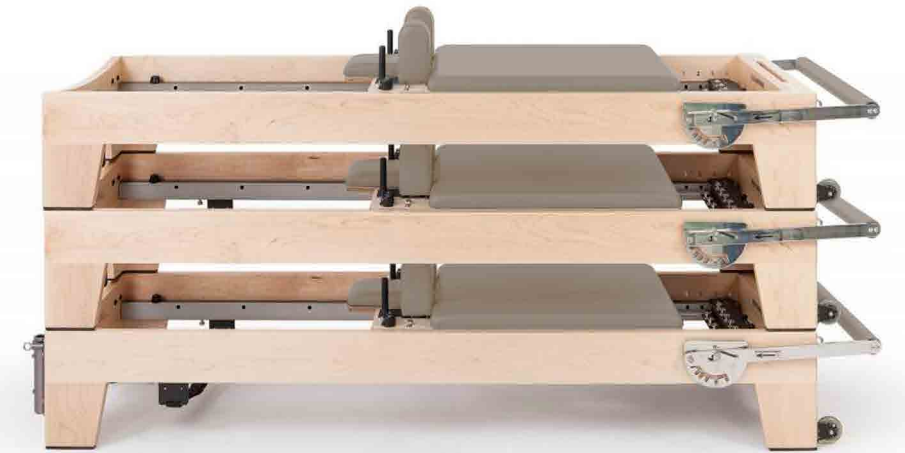

Dimensions: 245x76x40 cm.

ELITE REFORMER

ELN 700180

The professional reformer with maximum performance and functionality. It stands out for being the first stackable wooden reformer on the market.

Manufactured with the best materials and innovations, it is present in hundreds of studios around the world.





ELITE REFORMER WITH TOWER

ELN 700186

The professional reformer with maximum performance and functionality. It stands out for being the first stackable wooden reformer on the market.

Manufactured with the best materials and innovations, it is present in hundreds of studios around the world.



FEATURES

- > The same features as the Elite Reformer, adding the tower components.
- > Stainless steel towers with front and rear hooks for performing multiple exercises. It is easily disassembled.
- > Mat to cover the surface with handles. Very light.
- > Push Bar adjustable in 3 heights.
- > 1 push bar safety strap.
- > 4 positions spring bar and 2 rows of prestressed anchor.
- > Springs: 2 light (yellow), 2 medium (green) y 2 strong (red).
- > Roll-down bar in solid rock maple.
- > 1 set for simple handles for foot.
- > Height with the tower: 202 cm.
- > Different colors of upholstery.

Dimensions: 245x76x40 cm.

Height with tower: 202 cm.



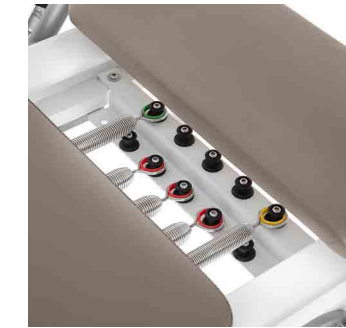
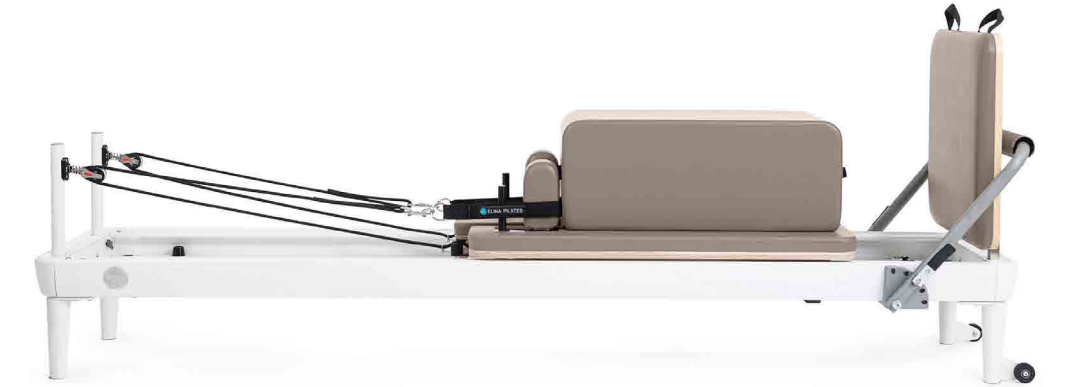

NUBIUM REFORMER

ELN 100306

The Elina Pilates Nubium reformer is a very functional Pilates machine that has a careful design with contemporary lines. Suitable for both home and professional use, it features a robust ergonomic structure made of white aluminum that provides a very comfortable and safe training experience.

The Nubium has an ultra-quiet trolley thanks to its eight polyurethane wheels and high-precision bearings that provide a smooth and silent movement.

FEATURES

- > Structure made of white aluminum.
- > Ultra-quiet trolley thanks to its eight special polyurethane wheels and high-precision bearings.
- > Automatic, retractable string adjustment system. Automatic rope collection retractable system that allows storing them in the lower part of the trolley.
- > High quality upholstery resistant to intense and continuous use.
- > Padded foot platform.
- > Fixed spring bar with 2 positions.
- > Padded foot bar, with quick change system of seven positions "Quick release".
- > Includes box and jumpboard.
- > Padded and lined double-looped hand/foot straps for comfort and control.
- > Includes adjustable foot strap.
- > Includes foot strap.
- > 3-position adjustable headrest.
- > Adjustable shoulder pads.
- > Springs: 2 strong (red), 2 medium (green) and 1 light (yellow).

Dimensions: 249x78x36 cm.
Weight: 63 kg (without accessories).







NUBIUM REFORMER WITH TOWER

ELN 300306

The Nubium Reformer by Elina Pilates stands out as a highly functional machine with an excellent quality-price ratio, making it ideal for both home and professional use. Made of high-quality white aluminum, the Nubium offers an exceptionally comfortable and safe training experience.

A distinctive feature of the Nubium is its ability to be stored vertically, which is especially useful for saving space in smaller areas.



FEATURES

- > Structure made of white aluminum.
- > Footbar with traditional system featuring 6 adjustable positions.
- > Padded, non-slip footbar and foot platform.
- > Smooth and ultra-silent carriage with eight polyurethane wheels and high-precision bearings.
- > High-quality upholstery resistant to intense and continuous use.
- > Retractable rope collection system that stores the ropes underneath the carriage.
- > Adjustable bed cushioning mechanism with 3 positions to prevent sudden impacts.
- > Complete set of five high-quality springs with fixed spring bar featuring two height levels to combine resistance according to desired intensity.
- > Complete set of 8 high-quality tower springs, short and long, to be placed along the tower.
- > Three-position adjustable headrest.
- > Padded, adjustable shoulder rests for easy setup.
- > Extra-wide padded box for enhanced stability.
- > Extra-wide removable jump board to facilitate foot placement.
- > Foot strap located on the inner part of the reformer.
- > Stainless steel tower with front and rear hooks for the springs.
- > Non-slip push-bar adjustable to 3 heights with safety strap.
- > Integrated wheels on the front legs to facilitate transport.

Dimensions: 249x78x36 cm.

Tower height: 102 cm.





NUBIUM BLACK EDITION REFORMER

ELN 100310

The Elina Pilates Nubium Black Edition reformer is a very functional Pilates machine that has a careful design with contemporary lines. Suitable for both home and professional use, it features a robust ergonomic structure made of black aluminum that provides a very comfortable and safe training experience.

The Nubium has an ultra-quiet trolley thanks to its eight polyurethane wheels and high-precision bearings that provide a smooth and silent movement. It has the same features as the Nubium Reformer.





NUBIUM BLACK EDITION REFORMER WITH TOWER

ELN 300310

The Nubium Reformer Black Edition by Elina Pilates is a limited edition that features the same design as the Nubium but in a fully black version, giving it a distinctive elegance.

A standout feature of the Nubium is its ability to be stored vertically, making it highly practical for small spaces. It also includes an ultra-silent carriage thanks to its eight polyurethane wheels with high-precision bearings, ensuring an exceptionally smooth and quiet glide.

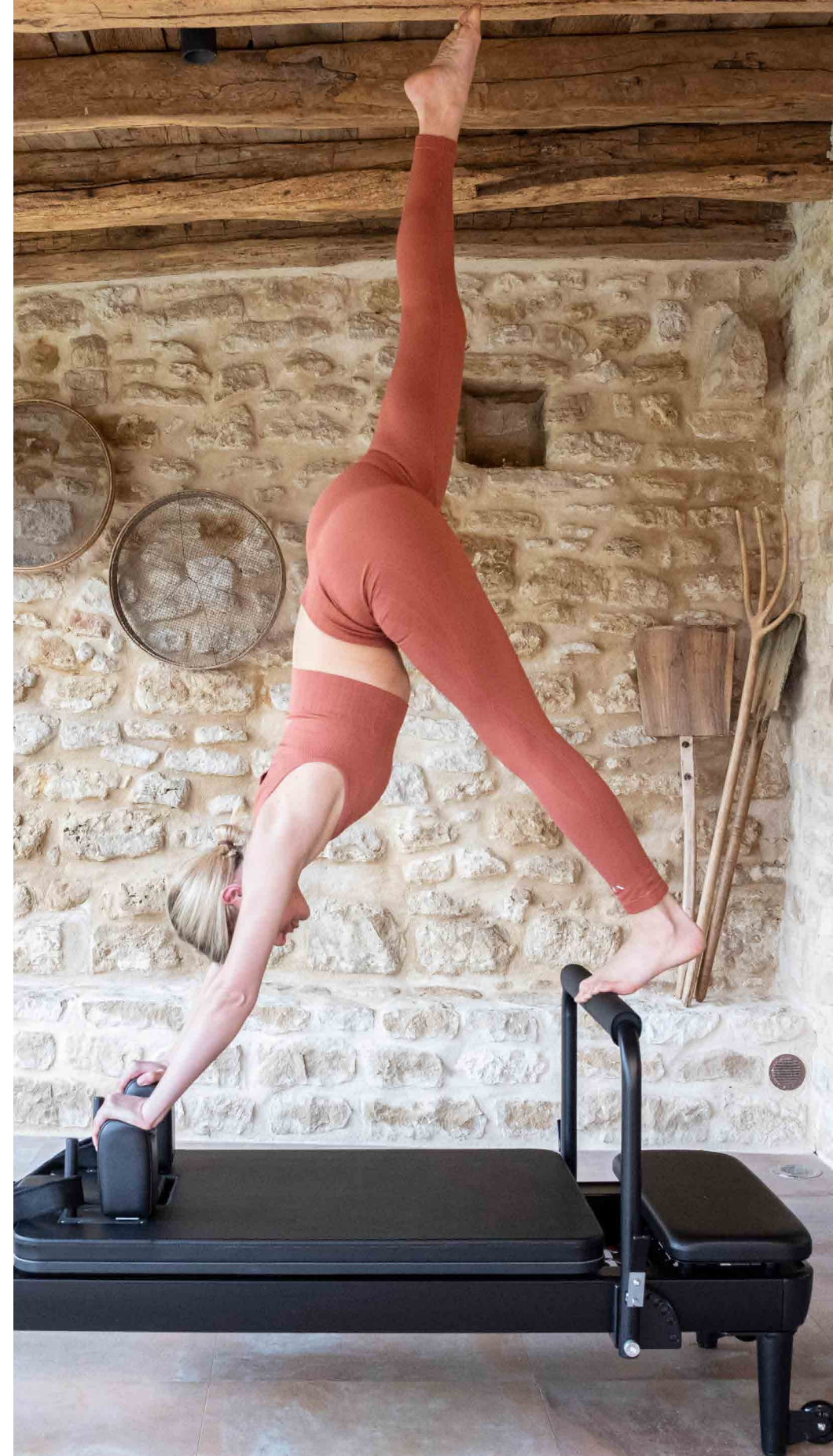

FEATURES

- > Same features as the Nubium Black Edition, with the addition of the tower components:
- > Stainless steel tower with front and rear hooks for the springs.
- > Complete set of 8 high-quality tower springs, both short and long, to be positioned along the tower.
- > Mat to cover the surface of the reformer, with handles.
- > Non-slip push-bar adjustable to 3 heights with safety strap.
- > Roll-down bar made of rock maple wood.

Dimensions: 249x78x36 cm.

Tower height: 102 cm.



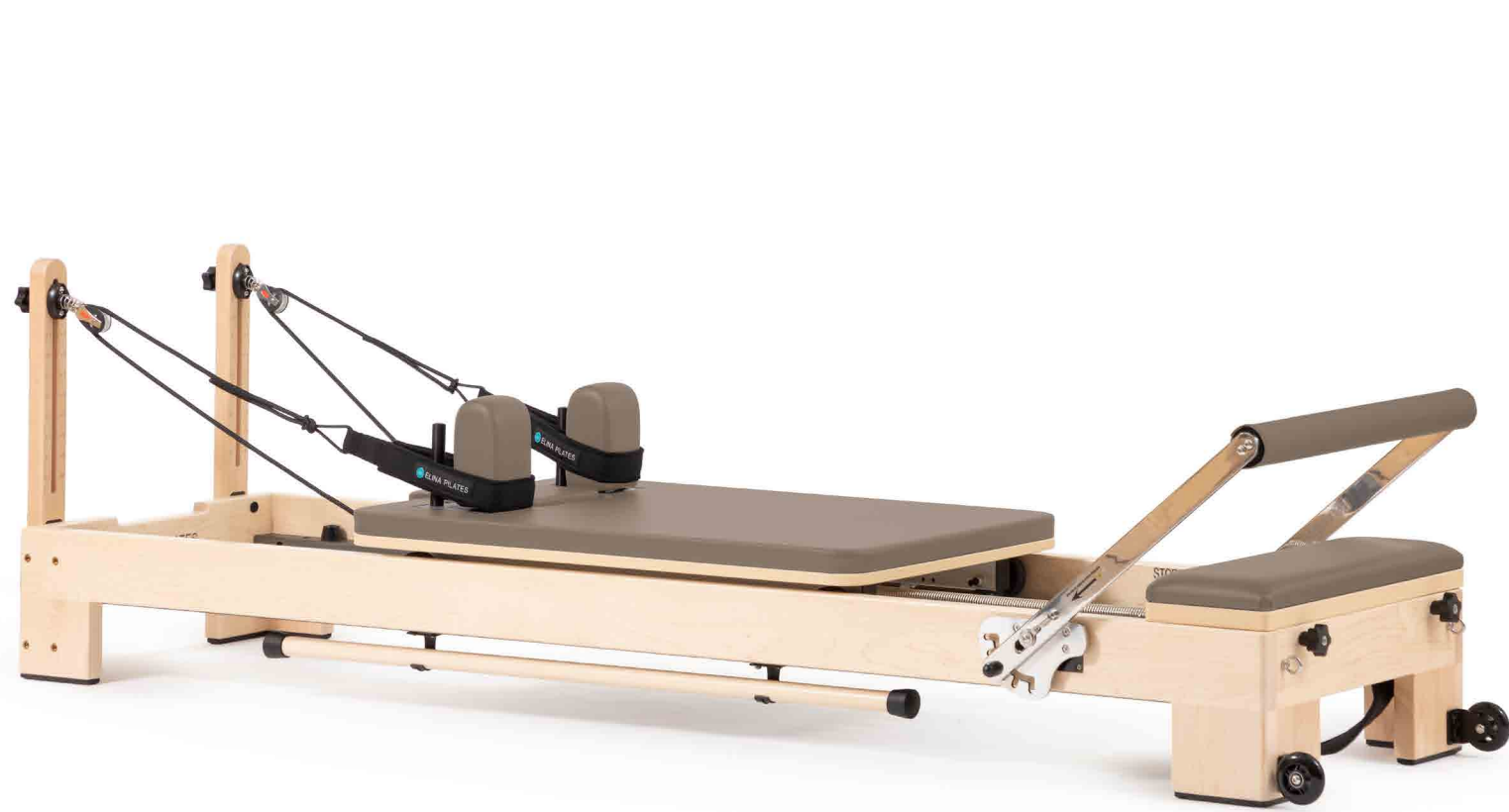

LIGNUM REFORMER

ELN 100506

The Lignum offers all the features of a professional reformer at a very reasonable price. Its excellent price-quality ratio makes the Lignum a recommendable machine both for domestic-private use and for professional use in commercial studios.

FEATURES

- > Structure made of light colored maple wood, with waterproof natural protection to protect the wood from wear and tear.
- > Padded footbar Quick Release system with 7 quick-change positions.
- > Trolley system with 8 polyurethane wheels that provide a smooth and silent tight parallel movement.
- > High quality upholstery for intensive use.
- > Headrest: 3 options.
- > Height adjustable pulleys.
- > Springs: 2 strong (red), 2 medium (green), 1 light (yellow).
- > Includes box and jumpboard.
- > Padded and lined double-loop hand/foot straps for comfort and control.
- > Includes foot strap.

Dimensions: 242x68x36 cm.





LIGNUM REFORMER WITH TOWER

ELN 300506

The Lignum offers all the features of a professional reformer at a very reasonable price.

Its excellent price-quality ratio makes the Lignum a recommendable machine both for domestic-private use and for professional use in commercial studios.



FEATURES

- > Same features as the Reformer Lignum, adding the components of the tower.
- > Stainless steel tower with front and rear attachments for performing multiple exercises. It can be easily disassembled.
- > Mat to cover the surface of the reformer.
- > Push bar adjustable in 3 heights with safety strap.
- > Springs: 2 short light (yellow), 2 short medium (green), 2 long light (yellow) and 2 long medium (green).
- > Rock maple roll-down bar.
- > 1 set of single foot straps.

Dimensions: 242x68x36 cm.

Height with tower: 194 cm.





WOOD REFORMER

ELN 700182

A dynamic and very comfortable machine. Ideal for studios looking for the cozy atmosphere provided by wood. Made of maple wood and stainless steel. Perfect stability and very resistant.

FEATURES

- > Shoulder removable pads.
- > Pulley bars with height change and removable quick-release system.
- > Silent and smooth slide system.
- > Adjustable headrest in 3 positions.
- > Adjustable foot bar in 4 positions.
- > Springs: 1 light (yellow), 2 medium (green), 2 strong (red).
- > A set of cotton handles for hands and feet and 1 set of padded handles.

- > Adjustable foot strap.
- > 1 set of pulley ropes.
- > Includes the jump board and the box.

Reformer dimensions: 237x69x33 cm.



WOOD REFORMER PHYSIO

ELN 700184

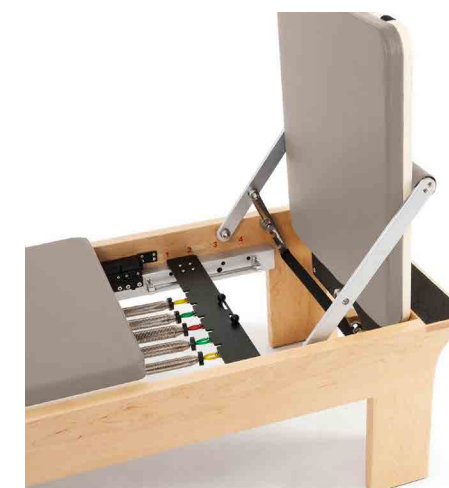

Physio Reformer dimensions: 237x69x48 cm.





WOOD REFORMER WITH TOWER

ELN 700188

A dynamic and very comfortable machine. Ideal for studios looking for the cozy atmosphere that wood provides. Made of maple wood and stainless steel. Perfect stability and very resistant.

FEATURES

- > Same characteristics as the Wood Reformer, adding tower components:
- > Stainless steel tower with front and rear hitch for Pilates exercises. Easy to remove.
- > Mat to cover the surface with handles. Very light.
- > Push Bar adjustable in 3 heights. 1 push bar safety strap.
- > 4 positions spring bar and 2 rows of prestressed anchor.
- > Springs: 2 light (yellow), 2 medium (green) y 2 strong (red).

- > Roll-down bar in solid rock maple.
- > 1 set for simple handles for foot.
- > Different colors of upholstery.

Reformer dimensions: 237x69x33 cm.

Wood Reformer height with tower: 202 cm.



WOOD REFORMER PHYSIO WITH TOWER

ELN 700190

Physio Reformer dimensions: 237x69x48 cm.

Physio Wood Reformer height with tower: 218 cm.



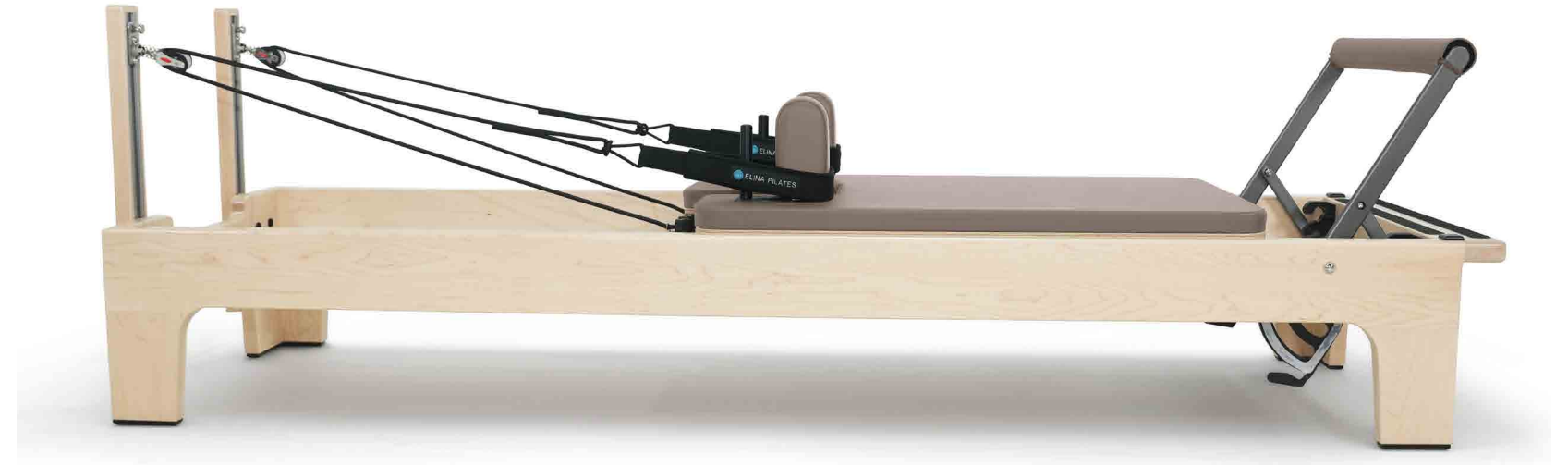

THE CLUB REFORMER

ELN 100526

The Club Reformer combines smoothness, silence, and versatility to deliver a perfect Pilates experience. Its premium design is created for instructors and users who seek comfort, safety, and performance in every movement.

FEATURES

- > Reformer made of maple wood
- > Footbar with a wide and stable design. Non-slip surface. Locking system that allows the bar to be adjusted in 4 positions.
- > Spring bar with a simple and intuitive lever adjustment system that allows the carriage to slide to the desired position, with two resistance options (neutral and preloaded) to customize intensity. Its sliding system moves the carriage closer to or farther from the footbar while maintaining balanced tension, and its 5 positions ensure optimal adaptation so each user can find their ideal setting with total comfort.
- > Retractable rope system.
- > Carriage cushioning system.
- > Smooth and ultra-quiet carriage with eight polyurethane wheels and high-precision bearings.
- > High-quality upholstery resistant to intensive and continuous use.
- > Rope adjustment system with cleats.
- > Complete set of 5 springs: 2 red, 2 green, 1 yellow.
- > Three-position adjustable headrest.
- > Padded and adjustable shoulder rests for easy placement.
- > Medium padded box with great stability.
- > Extra-wide removable jump board designed to facilitate proper foot placement.
- > Foot strap located in the well area, adjustable along the length of the machine.
- > Foot strap that can be positioned on both the inner and outer sides of the reformer.

Dimensions: 236×68.5×35 cm.





THE CLUB REFORMER WITH TOWER

ELN 300506

The Club Reformer with Tower combines smoothness, silence, and versatility to deliver a perfect Pilates experience. Its premium design is created for instructors and users who seek comfort, safety, and performance in every movement.



FEATURES

- > Reformer made of maple wood.
- > Footbar with a wide and stable design. Non-slip surface. Locking system that allows adjustment in 4 positions.
- > Spring bar with a simple and intuitive lever adjustment, allowing the carriage to slide to the desired position, with two resistance options (neutral and preloaded) to customize intensity. Its sliding system moves the carriage closer to or farther from the footbar while maintaining balanced tension, and its 5 positions ensure optimal adaptation so each user can find their ideal setting comfortably.
- > Retractable rope system.
- > Carriage cushioning system.
- > Smooth and ultra-quiet carriage with eight polyurethane wheels and high-precision bearings.
- > High-quality upholstery, resistant to intensive and continuous use.
- > Rope adjustment system with cleats.
- > Complete set of 5 springs: 2 red, 2 green, 1 yellow.
- > Three-position adjustable headrest.
- > Padded and adjustable shoulder rests, easy to place.
- > Medium padded box with excellent stability.
- > Extra-wide removable jump board designed for proper foot placement.
- > Foot strap located in the well area, adjustable along the length of the machine.
- > Foot strap can be positioned on both the inner and outer sides of the reformer.

Dimensions: 236 × 68.5 × 35 cm

Tower height: 197.5 cm





TWIN REFORMER

ELN 300616

The Twin Reformer offers a multitude of benefits, highlighting its exceptional versatility that makes it the perfect choice to stimulate your creativity and keep your Pilates workout always fresh.

With its double carriage design and resistances on both sides, this equipment allows you to focus on your body alignment.

The Twin Reformer is not only ideal for rehabilitation and recovery from injuries, but also for anyone wanting to improve their flexibility, strength and balance.

TOWER

- > Anti-slip hexagonal profiles.
- > Horizontal bar for ballet exercises and stretches.
- > Easy assembly and disassembly.
- > Adjustable pulleys in height and width.
- > Numbered on both its side and rear.
- > Adjustable hooks for the placement of springs or elastics on both the front and rear.

FEATURES

- > Maple wood protected with waterproof varnish.
- > Foot bar with "Quick release" system with 7 quick-change positions.
- > Padded, non-slip foot bar and board.
- > Mechanism that allows you to move the foot bar horizontally along the reformer, up to 28 different positions.
- > Smooth, ultra-quiet dual carriage with eight polyurethane wheels and high-precision bearings.
- > High-quality upholstery resistant to intense and continued use.
- > Rope adjustment with cleat system.
- > Complete set of twelve high-quality bed springs with a fixed spring bar at the front and rear of the reformer bed.
- > Complete set of 8 high-quality tower springs, short and long, to be placed along the tower.
- > Removable and fixed headrest.
- > Simple to place and remove adjustable padded shoulder pads.
- > Extra wide cushioned box of great stability that can be placed both parallel and perpendicular to the reformer.
- > Extra wide removable jumping board to facilitate foot placement.
- > Foot strap at the front of the reformer.
- > Mat to cover the surface of the reformer with handles.
- > Adjustable non-slip push-bar along the height and width of the tower.
- > Rock maple roll-down bar.
- > Integrated wheels on the front legs for easy transportation of the reformer.

Dimensions: 245 x 90 x 35 cm.

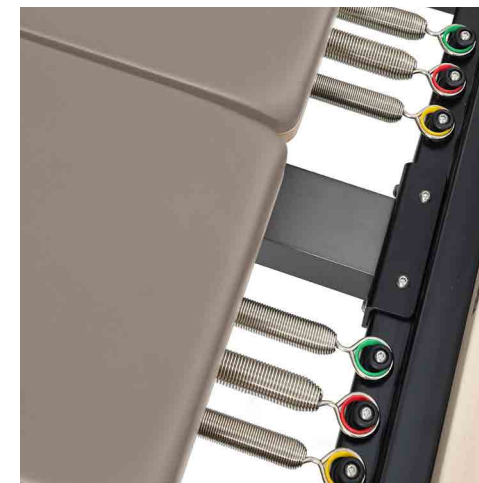



ALUMINIUM REFORMER HL3

ELN 200003

The most versatile model of Elina Pilates. Possibility to perform infinity exercises with the highest precision and safety. Reinforced structure in anodized aluminum. Possibility to stack it horizontally or placing it in a vertical position.

FEATURES

- > Silent and smooth slide system.
- > 6-position quick-change footbar.
- > Detachable pulley set and 1 pulley rope set.
- > Adjustable headrest in 3 positions.
- > 1 set of cotton handles for hands and feet and 1 set of padded handles.
- > Springs: 1 light (yellow), 2 medium (green), 2 strong (red).
- > Shoulder removable pads with fastening system.
- > Adjustable foot strap.
- > Includes the jump table and the box.
- > 1 anti-slip foot platform.
- > 2 wheels at the back for easy portability. 2 wheels to put it in a horizontal position.

Dimensions: 240x67x42 cm.



ALUMINIUM REFORMER HL1

ELN 200001



Dimensions: 240x67x22 cm.

ALUMINIUM REFORMER HL2

ELN 200002



Dimensions: 240x67x27 cm.

ALUMINIUM REFORMER HL4

ELN 200004



Dimensions: 240x67x62 cm.





ALUMINIUM REFORMER WITH TOWER HL3

ELN 400003

Our Aluminium Reformers with Tower are the only ones in the market that can be stacked horizontally without having to remove the tower. With a modern line, it incorporates the latest technological advances. The ideal reformer for studios and clubs looking for versatility and practicality.

FEATURES

- > Same characteristics of Aluminium Reformers but includes:
- > Steel folding tower. Allows the vertical movement of the pulleys throughout the guide.
- > 2 pulley extra sets for the tower.
- > Mat to cover the surface with handles. Very light.
- > Push Bar adjustable in 3 heights. 1 push bar safety strap.
- > Roll-down bar in solid rock maple.
- > Springs: 2 short light (yellow), 2 medium short (green), 2 light long (yellow) y 2 medium long (green).

- > 1 simple grip set for foot.
- > 1 height adjustable spring hitches set.
- > Different colors of upholstery.

Dimensions: 240x67x42 cm.

Height with tower: 197 cm.



ALUMINIUM REFORMER WITH TOWER HL1

ELN 400001



Dimensions: 240x67x22 cm.
Height with tower: 179 cm.

ALUMINIUM REFORMER WITH TOWER HL2

ELN 400002



Dimensions: 240x67x27 cm.
Height with tower: 190 cm.

ALUMINIUM REFORMER WITH TOWER HL4

ELN 400004



Dimensions: 240x67x62 cm.
Height with tower: 225 cm.



WORK OUT AT HOME



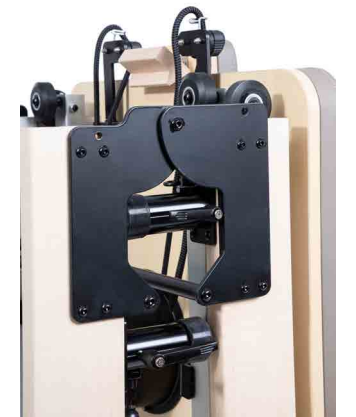

FOLD REFORMER

ELN 300686

The Elina Pilates Foldable Home Reformer is the perfect choice for those looking for a high-quality reformer with a professional design, yet adapted for home use. Its compact, foldable, and elegant structure, made from maple wood, ensures stability, firmness, and durability.

With our patented system, both parts of the reformer align perfectly when unfolded, eliminating the uncomfortable bump often felt when moving the carriage. Unlike other models that develop annoying gaps over time, our mechanism guarantees a consistently smooth, continuous, and seamless glide.

It includes everything needed for a complete workout in the comfort of your home. This reformer allows for hundreds of exercises suited for all levels, from beginner to advanced.

FEATURES

- > Made from light-toned maple wood.
- > Waterproof varnish that protects the wood from wear and tear.
- > Quick release system with six adjustable positions.
- > Padded bar to prevent slipping of feet and hands.
- > Ultra-quiet carriage thanks to its eight special polyurethane wheels and high-precision bearings.
- > Patented alignment system.
- > Retractable automatic cord storage system that allows cords to be stored at the bottom of the carriage.
- > Sophisticated bed cushioning mechanism that allows exercises to be performed smoothly, preventing noise and sudden impacts.
- > Adjustable padded shoulder rests for easy placement and removal.
- > Springs made from a high-quality, durable alloy that provides optimal resistance.
- > Adjustable headrest with three positions.
- > Removable foot support that is easy to place, with a lateral finish that facilitates gripping.

Dimensions: 235 x 61 x 28 cm (legs folded) – 35.5 cm (legs extended).

Folded Reformer Dimensions: 42 cm width (without foot bar) x 130 cm height x 66 cm depth. 73 cm width (with foot bar).

Weight: 72 kg (without accessories).





VERTICAL REFORMER

ELN 300646

The Elina Pilates Vertical Home Reformer is the perfect choice for those looking for a high-quality reformer with a professional design, yet adapted for home use. Its compact and elegant structure, made from maple wood, ensures stability, firmness, and durability.

This reformer is not only easy to transport and store in any corner of the home, but it also features a super-safe vertical storage system. Two removable legs provide a stable and firm base when stored, ensuring maximum safety when not in use.

To better adapt to each user's needs, the Vertical Reformer offers two bed height options, thanks to its adjustable legs (28 cm and 35.5 cm from the floor).

FEATURES

- > Made with light-toned maple wood.
- > Waterproof varnish that protects the wood from wear and tear.
- > Quick release system with six adjustable positions.
- > Padded bar to prevent slipping of feet and hands.
- > Ultra-quiet carriage thanks to its eight special polyurethane wheels and high-precision bearings.
- > Retractable automatic cord storage system that allows the cords to be stored at the bottom of the carriage.
- > Sophisticated bed cushioning mechanism that allows exercises to be performed smoothly, avoiding noise and sudden impacts.
- > Adjustable padded shoulder rests for easy placement and removal.
- > Springs made of a high-quality alloy with great durability, providing optimal resistance.
- > Adjustable headrest with three

- positions.
- > Removable foot support with easy placement, thanks to its lateral finish that facilitates gripping.

Dimensions: 235 x 61 x 28 cm (legs folded) – 35.5 cm (legs extended).

Weight: 62 kg (without accessories).





ELN 300600

DOMO REFORMER

Our reformer specially designed for domestic use. It is made of aluminum, which makes a strong and lightweight reformer.

Easy to fold, it takes up very little space and can be stored under a bed or in an upright position.



FEATURES

- > With telescopic folding system.
- > Foot bar with change in 3 positions + folding.
- > Adjustable headrest in 2 positions.
- > Shoulder pads and removable pulley bar.
- > With wheels for easy transport.
- > It can be placed vertically comfortably.
- > 5 professional springs: 1 strong, 2 medium and 2 light.
- > Optional jump board and box.

Measures: 238x58x16 cm (bed height)

Folded measures: 149x58x16 cm.

Vertical measures: 149x58x50 cm.

Weight: 40 kg.





C
L
A
S
S
I
C

A
L
U
M
I
N
I
U
M

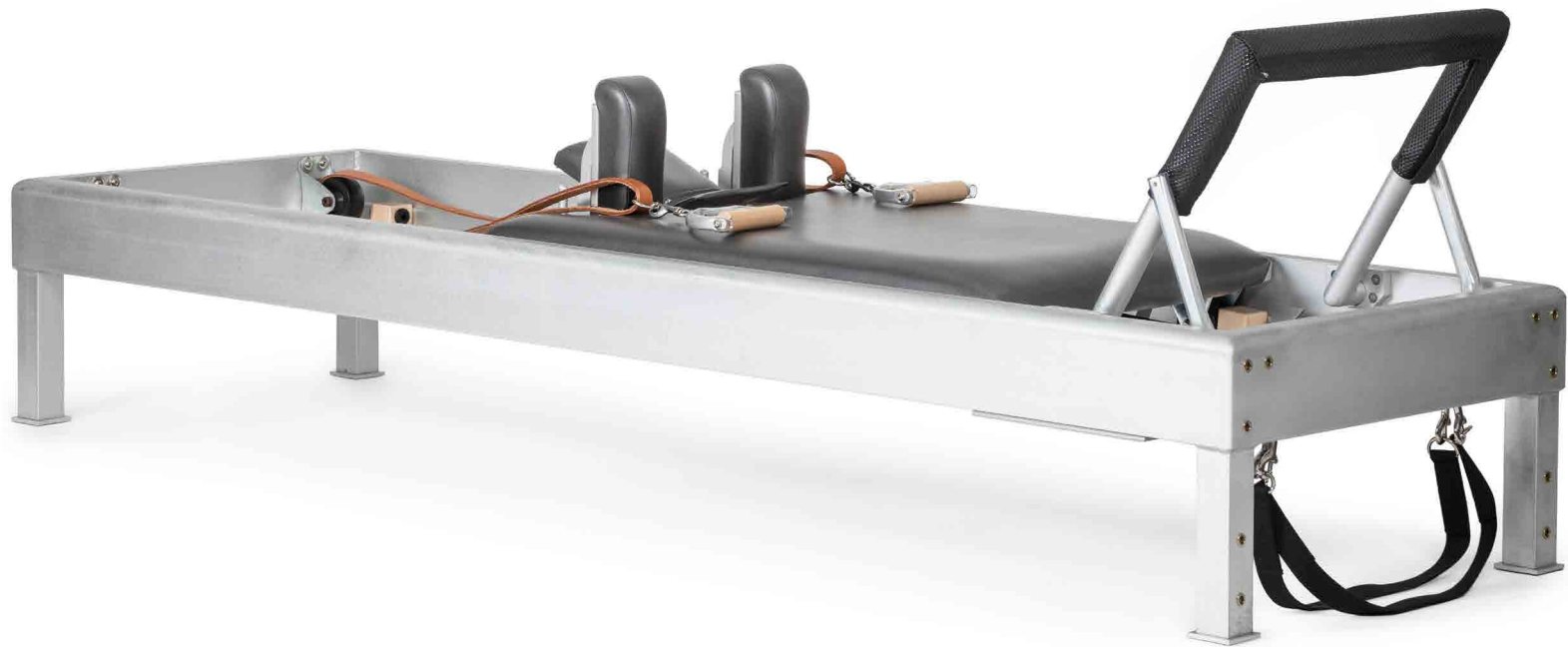

CLASSIC ALUMINUM REFORMER 86"

ELN 100206

Classic design according to the legacy left by Joseph Pilates, creator of the Pilates method.

Reformer with reinforced structure of compact anodized aluminum of great resistance. With long lasting leather upholstered bed filled with very comfortable high density EVA foam. Fully functional and versatile, it allows to perform a wide variety of exercises with total precision, comfort and safety.



INCLUDES

- > The classic reformer includes:
- > Natural leather straps.
- > Aluminum spike.
- > Foot straps for securing the feet.
- > A pair of wooden handles.
- > 4 classic-style springs
- > Classic box and padded jump board platform.

Dimensions: 220x66x35 cm.

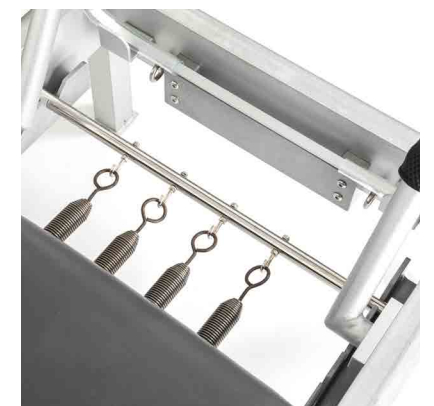



CLASSIC ALUMINIUM REFORMER 86" WITH TOWER

ELN 300106

Classic design according to the legacy left by Joseph Pilates, creator of the Pilates method.

Reformer with tower designed in a compact anodized aluminum reinforced structure of great resistance. With long lasting leather upholstered bed filled with very comfortable high density EVA foam. Fully functional and versatile, it allows to perform a wide variety of exercises with total precision, comfort and safety.



FEATURES

- > Same features as the Classic Reformer, adding the tower components:
- > Steel tower with safety chains.
- > Set of 8 springs: 2 leg springs, 2 arm springs, 2 push-through bar springs, and 2 roll-down bar springs.

- > Wooden push-thru bar and roll-down bar.
- > Mat to cover the surface.
- > 1 set of foot handles.

Dimensions: 220x66x35 cm.

Height with tower: 185 cm.





CLASSIC NATURAL WOOD REFORMER

ELN 300106

The 86" Classic Natural Maple Wood Reformer is an iconic piece designed to take your Pilates practice to the next level. Inspired by the legacy of Joseph Pilates, this reformer embodies the essence of the original Pilates method while incorporating contemporary improvements that ensure a smooth, precise, and long-lasting experience.

Crafted from solid natural maple wood, this equipment stands out for its elegance, stability, and durability, making it an ideal choice for both professional studios and discerning practitioners. Every detail has been carefully designed to honor the authenticity of the classical method: natural leather straps, traditional metal pole, and wooden handles—elements that evoke the craftsmanship of original classical Pilates while delivering the reliability and quality demanded by today's training.

FEATURES

- > Structure made of 86" maple wood.
- > Classic footbar.
- > Padded, non-slip classic footboard.
- > High-quality upholstery, resistant to intense and continuous use.
- > Natural leather straps.
- > Classic wooden handles.
- > Adjustable stopper mechanism for the carriage, both at the head end (2 positions) and the foot end (adjustable in 3 positions).
- > Complete set of four classic springs with an adjustable spring bar in 3 positions to combine resistances according to desired intensity.
- > Adjustable headrest with 3 positions.
- > Removable padded shoulder rests, easy to place.
- > Stable padded classic box.
- > Removable padded classic jump board, easy to position.
- > Foot straps that can be placed both at the front of the reformer and on the inner side under the footbar.

Dimensions: 225 × 66 × 35 cm.



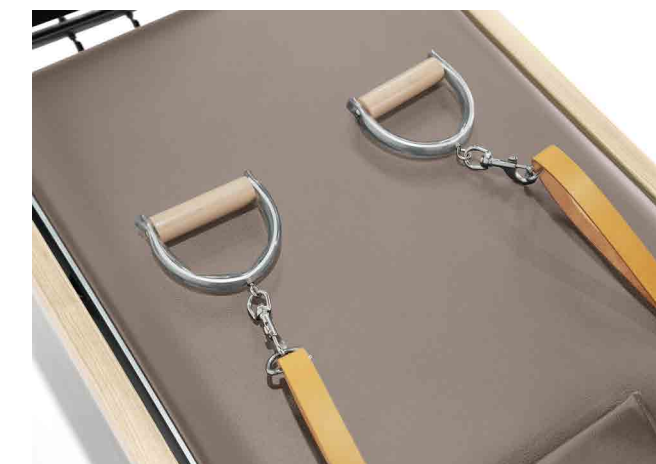
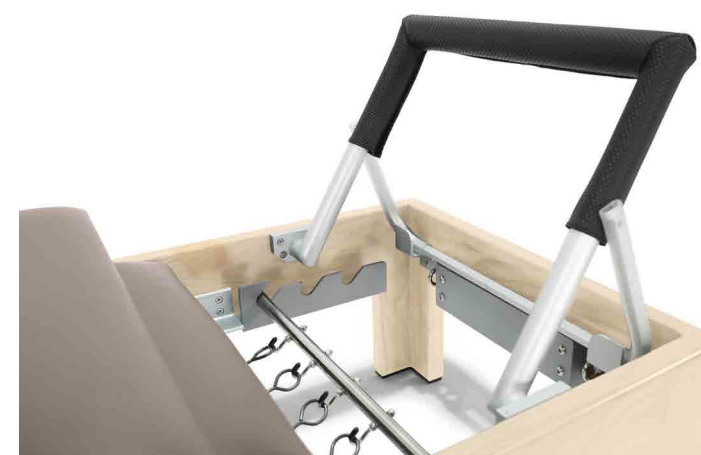

CLASSIC NATURAL WOOD REFORMER WITH TOWER

ELN300121

The 86" Classic Natural Maple Wood Reformer with Tower is an iconic piece designed to elevate your Pilates practice to the next level. Inspired by the legacy of Joseph Pilates, this reformer embodies the essence of the original Pilates method while incorporating contemporary enhancements that ensure a smooth, precise, and long-lasting experience.

Crafted from solid natural maple wood, this equipment stands out for its elegance, stability, and durability, making it an ideal choice for both professional studios and discerning practitioners. Every detail has been carefully designed to honor the authenticity of the classical method: natural leather straps, traditional metal pole, and wooden handles—elements that evoke the craftsmanship of original classical Pilates while delivering the reliability and quality required by today's training.

FEATURES

- > Structure made of 86" maple wood.
- > Classic footbar.
- > Padded, non-slip classic footboard.
- > High-quality upholstery, resistant to intense and continuous use.
- > Natural leather straps.
- > Classic wooden handles.
- > Adjustable stopper mechanism for the carriage, both at the head end (2 positions) and the foot end (adjustable in 3 positions).
- > Complete set of four classic springs with an adjustable spring bar in 3 positions to combine resistances according to desired intensity.
- > Complete set of eight high-quality classic tower springs: 2 for legs, 2 for arms, 2 for bar, and 2 for push bar.
- > Adjustable headrest with 3 positions.
- > Removable padded shoulder rests, easy to place.
- > Stable padded classic box.
- > Removable padded classic jump board, easy to position.
- > Foot straps that can be placed both at the front of the reformer and on the inner side under the footbar.
- > Stainless steel tower with front and rear attachments for the springs.
- > Mat to cover the surface of the reformer.
- > Wooden push-bar.
- > Steel safety chains.
- > Wooden roll-down bar.

Dimensions: 225 × 66 × 35 cm.

Maximum height with tower: 183.5 cm.





FEATURES

- > Frame made of maple wood.
- > Footbar with a 3-position system.
- > Padded, non-slip footbar and standing platform.
- > High-quality upholstery, resistant to intensive and continuous use.
- > Padded and adjustable shoulder rests, easy to place.
- > Medium padded box with excellent stability.
- > Removable jump board.
- > Stainless steel trapeze with front and rear attachments for springs
- > Mat to cover the reformer surface.
- > Non-slip push-bar adjustable to 3 heights, with safety strap.
- > Roll-down bar made of solid maple wood.



CLASSIC NATURAL WOOD CADILLAC REFORMER

ELN100226

The Complete Natural Wood Cadillac Reformer by Elina Pilates combines the versatility of the classic reformer with the functionality of a Cadillac, creating a professional machine designed to provide the complete Pilates system in a single apparatus. It allows for a wide variety of exercises without the need for two separate machines, optimizing studio space while delivering the most comprehensive training experience.

Crafted from high-quality natural maple wood, its frame stands out for the strength, stability, and elegance this material provides. The natural grains and tones of the wood give each machine a unique character, adding a warm and sophisticated style to any studio.



CLASSIC WALNUT WOOD REFORMER

ELN100246

The 86" Classic Walnut Wood Reformer is an iconic piece designed to elevate your Pilates practice to the next level. Inspired by the legacy of Joseph Pilates, this reformer embodies the essence of the original Pilates method while incorporating contemporary enhancements that ensure a smooth, precise, and long-lasting experience.

Crafted from walnut wood, this equipment stands out for its elegance, stability, and durability, making it an ideal choice for both professional studios and discerning practitioners. Every detail has been carefully designed to honor the authenticity of the classical method: natural leather straps, traditional metal pole, and wooden handles—elements that evoke the craftsmanship of original classical Pilates while delivering the reliability and quality demanded by today's training.

FEATURES

- > Structure made of 86" walnut wood.
- > Classic footbar.
- > Padded, non-slip classic footboard.
- > High-quality upholstery, resistant to intense and continuous use.
- > Natural leather straps.
- > Classic wooden handles.
- > Adjustable stopper mechanism for the carriage, both at the head end (2 positions) and the foot end (adjustable in 3 positions).
- > Complete set of four classic springs with an adjustable spring bar in 3 positions to combine resistances according to desired intensity.
- > Adjustable headrest with 3 positions.
- > Removable padded shoulder rests, easy to place.
- > Stable padded classic box.
- > Removable padded classic jump board, easy to position.
- > Foot straps that can be placed both at the front of the reformer and on the inner side under the footbar.

Dimensions: 225 × 66 × 35 cm.





CLASSIC WALNUT WOOD REFORMER WITH TOWER

ELN100246

The 86" Classic Walnut Wood Reformer with Tower is an iconic piece designed to elevate your Pilates practice to the next level. Inspired by the legacy of Joseph Pilates, this reformer embodies the essence of the original Pilates method while incorporating contemporary enhancements that ensure a smooth, precise, and long-lasting experience.

Crafted from walnut wood, this equipment stands out for its elegance, stability, and durability, making it an ideal choice for both professional studios and discerning practitioners. Every detail has been carefully designed to honor the authenticity of the classical method: natural leather straps, traditional metal pole, and wooden handles—elements that evoke the craftsmanship of original classical Pilates while delivering the reliability and quality demanded by today's training.



FEATURES

- > Structure made of 86" walnut wood.
- > Classic footbar.
- > Padded, non-slip classic footboard.
- > High-quality upholstery, resistant to intense and continuous use.
- > Natural leather straps.
- > Classic wooden handles.
- > Adjustable stopper mechanism for the carriage, both at the head end (2 positions) and the foot end (adjustable in 3 positions).
- > Complete set of four classic springs with an adjustable spring bar in 3 positions to combine resistances according to desired intensity.
- > Complete set of eight high-quality classic tower springs: 2 for legs, 2 for arms, 2 for bar, and 2 for push bar.
- > Adjustable headrest with 3 positions.
- > Removable padded shoulder rests, easy to place.
- > Stable padded classic box.
- > Removable padded classic jump board, easy to position.
- > Foot straps that can be placed both at the front of the reformer and on the inner side under the footbar.
- > Stainless steel tower with front and rear attachments for the springs.
- > Mat to cover the surface of the reformer.
- > Wooden push-bar.
- > Steel safety chains.
- > Wooden roll-down bar.

Dimensions: 225 × 66 × 35 cm.

Maximum height with tower: 183.5 cm.





CLASSIC WALNUT WOOD CADILLAC REFORMER

ELN 100246

The Complete Dark Wood Cadillac Reformer by Elina Pilates, made from walnut wood, combines the versatility of the classic reformer with the functionality of a Cadillac, creating a professional machine designed to provide the complete Pilates system in a single apparatus. It allows for a wide variety of exercises without the need for two separate machines, optimizing studio space while delivering the most comprehensive training experience.

Crafted from high-quality walnut wood, its frame stands out for the strength, stability, and elegance this material provides. The natural grains and tones of the wood give each machine a unique character, adding a warm and sophisticated style to any studio.

FEATURES

- > Frame made of walnut wood.
- > Footbar with a 3-position system.
- > Padded, non-slip footbar and standing platform.
- > High-quality upholstery, resistant to intensive and continuous use.
- > Padded and adjustable shoulder rests, easy to place.
- > Medium padded box with excellent stability.
- > Removable jump board.
- > Stainless steel trapeze with front and rear attachments for springs.
- > Mat to cover the reformer surface.
- > Non-slip push-bar adjustable to 3 heights, with safety strap.
- > Roll-down bar made of solid maple wood.





COREXTREME

ELN 100916

CoreXtreme combines power, resistance, and control in a single machine. Designed for high-intensity workouts, it features 8 steel springs and a sturdy frame that ensures precision and stability in every movement, making it ideal for studios and gyms seeking maximum quality and durability. Perfect for a high-intensity, low-impact training method, CoreXtreme merges strength, cardio, and control under continuous tension. It develops muscular endurance, power, and flexibility while minimizing impact and taking performance to the highest level.

FEATURES

- > Frame made of aluminum.
- > Padded, non-slip footboard.
- > Smooth and ultra-quiet carriage.
- > High-quality upholstery, resistant to intensive and continuous use.
- > Adjustable stopper mechanism.
- > Complete set of 8 springs.
- > Removable padded shoulder rests, easy to place.
- > Classic padded box with excellent stability.

Dimensions: 327.7 × 66 × 45.3 cm



INCLUDES

- > 4 metal handbars (iron) rotate 360°.
- > 8 wheels under the sliding platform (4 parallel wheels + 4 load-bearing wheels).
- > 2 cup holders on the frame. Allows adjustment of the foot pedals in four angles.
- > Includes: 8 springs, box, metal corrective roller (iron), 5 foot straps, 3 pairs of ropes (1.5 m; 1.7 m; 2.7 m).
- > D-type handles.
- > Double-loop traction straps.
- > 4 carabiners.
- > 4 O-shaped carabiners.
- > 2 resistance bands with fixed grips.
- > Back platform.
- > Rotating rear handlebars.
- > Handlebar strap.
- > Nylon strap.
- > Other option: cable.
- > Adjustable rowing-type shoulder support.
- > Front platform.
- > Front handlebar.
- > Rotating top part.
- > Rotating bottom part.
- > Bottom adjustable in 4 positions.
- > Two 1 kg dumbbells.
- > 2 dumbbells of 2 kg.



C
A
D
I
L
L
A
C
S



ELITE CADILLAC REFORMER

ELN 700192

Exclusive and modern design. Best benefits to professionals in the sector.
 It incorporates innovative systems such as the push bar, the quick change of foot bar positions, a bar for 6 springs and quick-adjustment pulleys.





FEATURES

- > The carriage runs on a two-piece rail system that provides a stable, smooth, and silent glide, featuring a strong internal frame, adjustable alignment control, and foam padding.
- > The carriage uses an eight-wheel system: four vertical wheels to support the carriage and four adjustable lateral wheels to keep it perfectly aligned between the frames.
- > It includes comfortable padded surfaces, highlighted by a cervical support with a three-position headrest, two quick-release shoulder rests adjustable in four positions, a large padded and upholstered jump board, and a foot bar adjustable in seven positions.
- > As a result of significant innovation, the reformer also features our new chair push bar. This integrates the Pilates Chair concept directly into the Cadillac-Reformer, creating a very compact solution that helps optimize space.
- > It includes two springs (red), although the push bar can be connected using either one spring or both springs simultaneously.

Dimensions: 248x88x56 cm.

Height with tower: 220 cm.



INCLUDES

- > Adjustable shoulder pads to 4 positions, easy adaptation to each user.
- > Adjustable headrest in 3 positions.
- > Stainless steel tower with front and rear hitch for Pilates exercises. Easy to remove.
- > Pulley bars with quick height change and removable quick-release system.
- > 7-position quick-change footbar.
- > Push Bar adjustable in 4 heights.
- > 1 push bar safety strap.
- > Wooden trapeze bar with padded protection, with covered springs for greater safety and stabilizer belt.
- > 1 set of pulley ropes, 1 adjustable foot strap.
- > 1 adjustable box strap.
- > 1 velcro strap.
- > Roll-down bar in solid maple wood.
- > Springs : 2 light (yellow), 2 medium (green) and 2 strong (red).
- > 1 spring bar with 4 positions and 2 rows of prestressed anchors.
- > 2 long green springs for the chair, 1 chair frame and 1 set of supports with sliding along the pit.
- > 1 set of double cotton padded handles for hands and feet, 1 set for feet and 1 set of padded handles.
- > 1 pair of Fuzzies handles , very soft, 1 stopper with sliding along the structure and 2 bars for horizontal and vertical sliding, with quick adjustment system.
- > Includes the jump board, Box, anti-slip foot platform and Standing Platform for the feet and double mat to completely cover the surface.
- > 1 set of double cotton padded



CADILLAC REFORMER

ELN 700194

The Cadillac Reformer is made of premium Maple wood. Very resistant. All metal parts in stainless steel and anodized aluminum.

Upholstered leather bed with very long durability, specially developed for our products.

High density EVA foam padding, very comfortable, ideal for Pilates. Meets environmental regulations.



THE CADILLAC INCLUDES

- > Double mat to completely cover the surface.
- > 2 horizontal and vertical sliding bars with quick adjustment system.
- > Foot support mat.
- > Adjustable fastening strap.
- > Wooden trapeze bar with padded protection, with covered springs for greater safety and stabilizer belt.
- > Springs: 2 short light (yellow), 2 short medium (green), 2 light long (yellow) and 2 medium long (green).
- > Roll-down bar in solid beech wood.
- > 1 pair of Fuzzies grips, very soft.

THE REFORMER INCLUDES

- > Stainless steel towers with hooks. Easier exercises from outside of the unit. Easily removable.
- > Pulley bars with height change and removable quick-release system .
- > Adjustable headrest in 3 positions.
- > Removable shoulder pads .
- > 1 set of pulley ropes.
- > Adjustable foot bar in 4 positions.
- > Push bar adjustable in 4 heights.
- > 1 push bar safety strap.
- > Bed Springs: 2 light (yellow), 2 medium (green), 2 strong (red).
- > 1 set of double cotton padded handles for hands and feet, 1 set for feet and 1 set of padded handles.
- > Adjustable foot strap.
- > Includes the jump board and the box.

Dimensions: 240x78x56 cm.

Height with tower: 215 cm.





WOOD CADILLAC

ELN 700196

Made of first quality Maple wood. Perfect stability, very resistant. All metal parts in stainless steel and anodized aluminum. Upholstered leather bed with very long durability, specially developed for our products.

High density EVA foam padding, very comfortable, ideal for Pilates. Meets environmental regulation



INCLUDES

- > Headrest.
- > Wooden trapeze bar with padded protection, with covered springs for greater safety and stabilizer belt.
- > Push-bar adjustable in 3 heights.
- > 1 push-bar safety strap.
- > Roll-down bar in solid beech wood.
- > Standing Platform for the feet of the Reformer.
- > 2 horizontal and vertical sliding bars with quick adjustment system.
- > Springs : 2 short light (yellow), 2 short medium (green), 2 light long (yellow) and 2 medium long (green).
- > 1 set of padded handles.
- > 1 set of Fuzzies handles , very soft.
- > Adjustable foot strap.
- > Adjustable fastening strap.
- > Different colors of upholstery.

Dimensions: 251x78x58 cm.

Height with tower: 215 cm.





CLASSIC ALUMINIUM CADILLAC

ELN 100206

Classic design according to the legacy left by Joseph Pilates, creator of the Pilates method.

Classic Cadillac made of compact, heavy-duty stainless aluminum. Durable leather upholstered bed filled with comfortable high density EVA.



INCLUDES

- > Steel frame with safety chains.
- > Set of 8 springs:
- > 2 leg springs, 2 arm springs, 2 push-through bar springs and 2 roll-down bar springs.
- > Wooden push-thru bar and roll-down bar.
- > 2 loop straps for legs.
- > 2 Fuzzies handles.
- > Upholstered trapeze bar.
- > Kuna board.

Dimensions: 220x68x63 cm.

Height with tower: 210 cm.

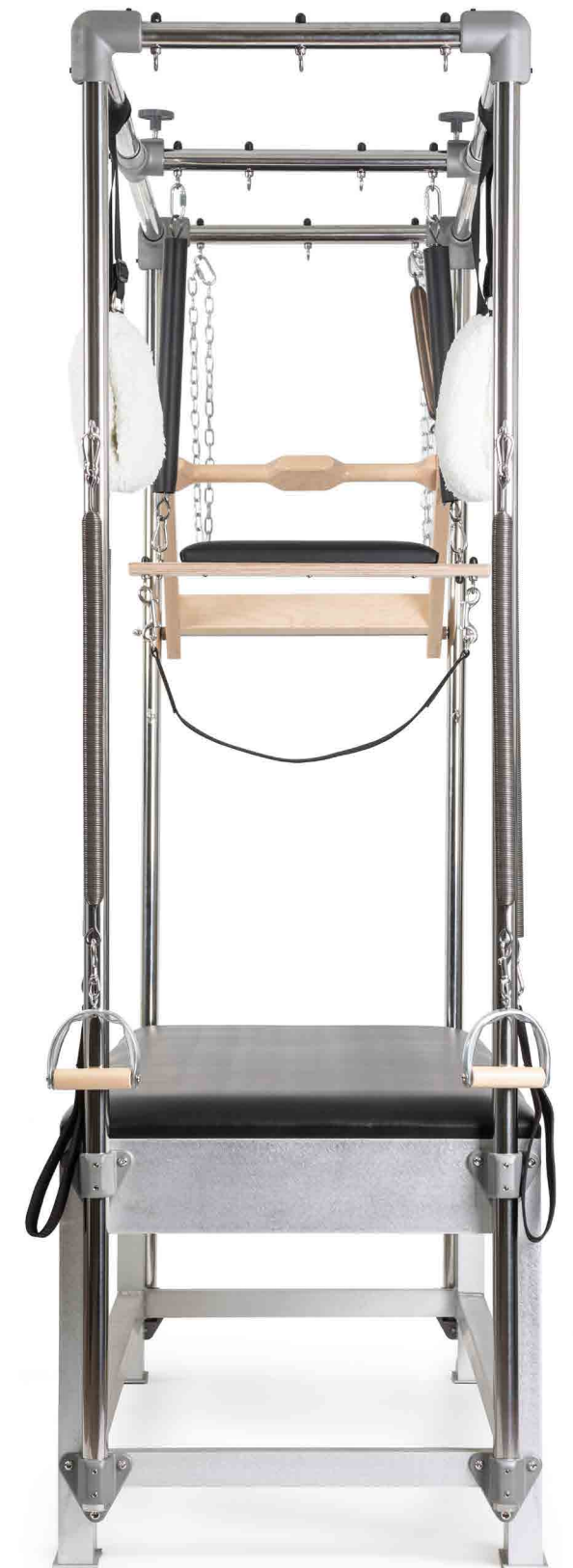



ONNE

Experience has always been a determining factor in creating innovative Pilates machines and, in the development of the Wall Board ONNE, it has been more important than ever. The combination of the experience of the renowned Pilates trainer Eva Espuelas and the manufacturing know-how of Elina Pilates have resulted in a new machine capable of satisfying the needs of the most demanding.

Versatility, elegant design, dimensions, adaptability and ease of use are just some of the characteristics that can define this unique 100% Spanish-made product. Revolutionizing the concept of the traditional Wall Board, the use of space offered by ONNE allows the work of Pilates Machines to be carried out by larger groups, as well as incorporating new elements that multiply the functionalities of its use, offering the user the possibility of enjoying 5 machines in one.

In addition to its careful aesthetics and adaptability systems to the specific measurements of each person and training, ONNE is a unique machine that incorporates features for the work of different machines such as the Cadillac, PED-PULL, Inclined Platform, Ballet Bar and Training in Suspension, achieving with all of them an exceptional performance, since all the components of the training are worked on.

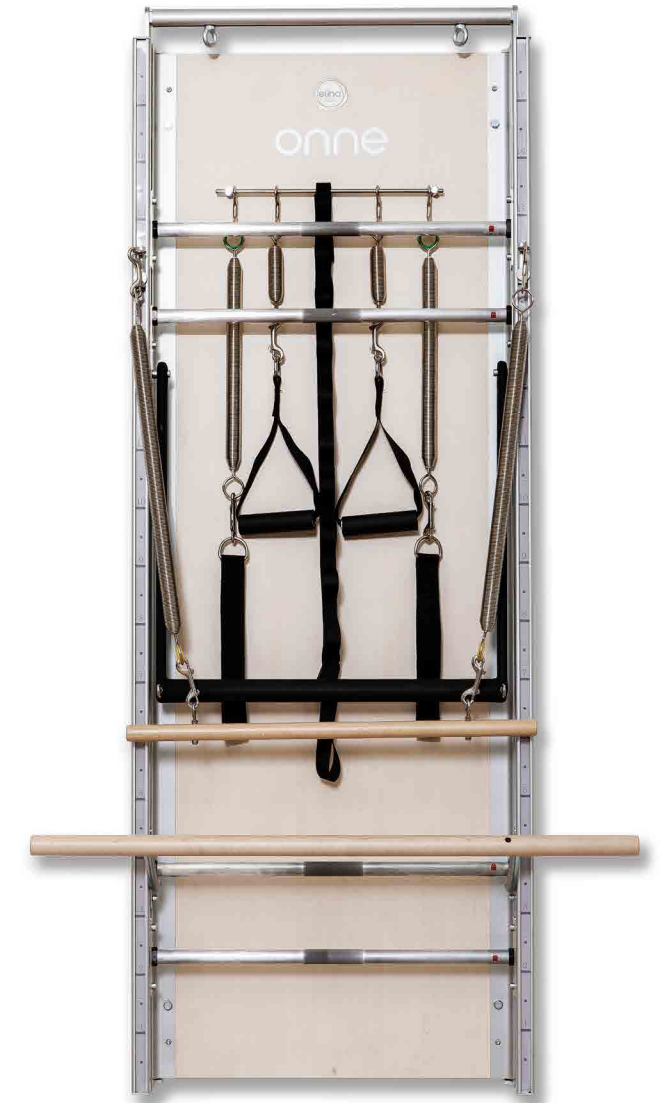

WALL BOARD ONNE

It is a unique machine that is characterized by its versatility, and is also an excellent option for those who need to take advantage of space.

5 MACHINES IN ONE:

Cadillac + Ped-Pull + Inclined Platform + Ballet Bar + Suspension Training.

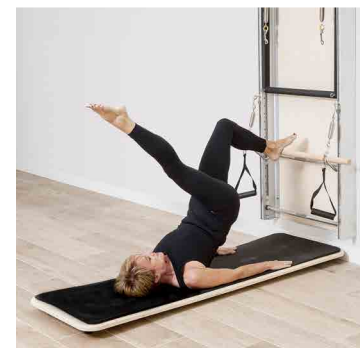

INCLUDES

Among the innovative elements that it incorporates are:

> **INCLINED PLATFORM:**

It maximizes results since it provides the performance of exercises on this plane, making them more complex depending on the degree of inclination that you want to exploit, achieving adaptations that cannot be developed on the ground. This platform is easy to store and clean and its non-slip mat can be easily removed and replaced.

> **BALLET BAR:**

Cylindrical piece of wood that allows bodybuilding exercises and helps correct postural positioning.

> **BELT:**

Element that can be used to carry out suspended work.

> The ONNE Wall Board, made with the best materials and the characteristic quality of Elina Pilates products, is a solution that saves space, providing the user with the possibility of performing countless exercises on a single machine.

> Made of wood and aluminum, ONNE is fully adjustable and ready to be anchored to the wall.



FEATURES

- > Wall Board.
- > Wooden mat table with non-slip mat and regulable base.
- > Ballet bar. Regulable height.
- > Roll-down bar.
- > Regulable push-bar.
- > Regulable Ped-Pull.
- > Hanger for springs and accesories.
- > Spring handle. Regulable height.
- > Springs: 2 long light (yellow), 2 short medium (green) y 2 short.
- > Handle complete set (foot handle and padded handle).
- > Adjustable fastening strap.

ELN 300021

BASIC

Without ballet bar and without mat table.

ELN 300022

FULL EQUIP

With ballet bar and without mat table.

Machine width: 68,5 cm.

Width with ballet bar: 100 cm.

Height: 209 cm.

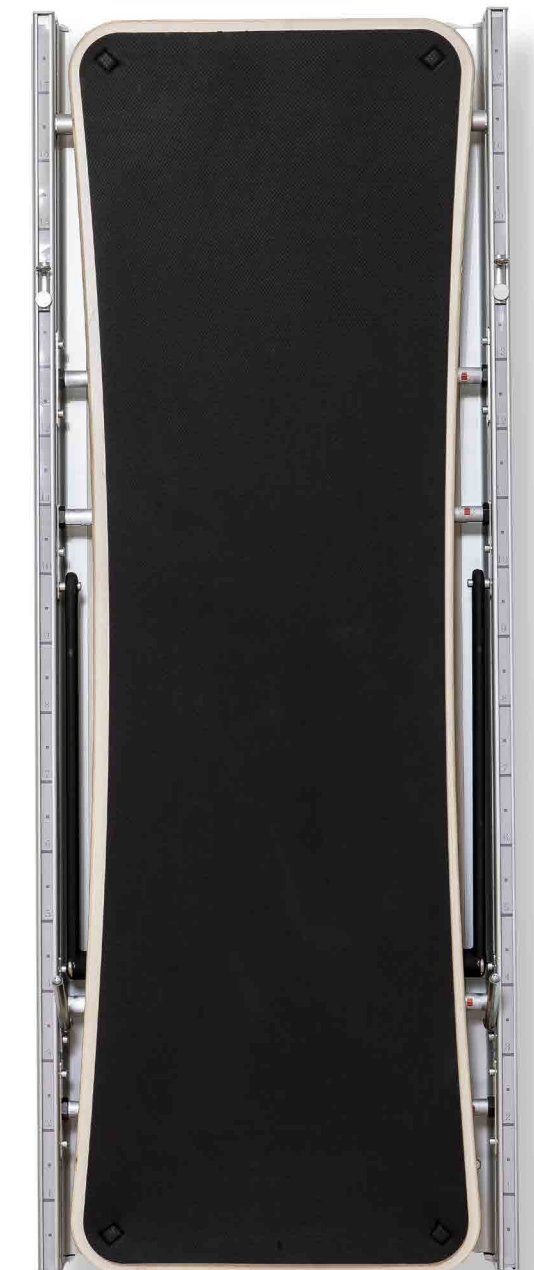

WALL UNIT

ELN 700230

Elina Pilates' Wall Units are one of the most requested products by the classic Pilates studios. Manufactured with high quality and durability materials. Covered with special leather for Pilates. Structure of reinforced wood, very resistant. Anti-slip, ecofriendly materials.

High density EVA filling. Very comfortable. Wall Unit Pilates is the ideal machine for the practice of Pilates in places where we have little space.

TOWER

- > Stainless steel tower. Easy to remove.
- > Anodized aluminum pull-up bar with handle rubber and padded protection. With safety strap.
- > Top and down springs. Adjustable in 3 positions.
- > Spring complet set.
- > Handles complet set.
- > Roll-down wood pole made of solid beech.
- > Push-bar, adjustable in 3 positions.
- > Stability sling.

Tower size: 215x69cm.

Bed size: 220x63x18,5 cm.

Boxes size: 30x42x18,5cm.



WALL BOARD

ELN 300020

Versatility, elegant design, dimensions, adaptability, and ease of use are just some of the features that make this product unique.

Made with high-end materials, this wall unit is a space-saving solution that allows users to perform countless exercises on a single machine. Crafted from wood and aluminum, it is adjustable and designed to be securely mounted on the wall.

INCLUDES

- > 2 long springs - Yellow (light resistance)
- > 2 long springs - Green (medium resistance)
- > 2 short springs - Yellow (light resistance)
- > 2 short springs - Green (medium resistance)
- > One pair of hand straps
- > One pair of soft foot straps
- > Solid wood Roll Down Bar
- > Solid wood dowel (lower bar)
- > Push bar with five height positions
- > Safety strap for trapeze
- > Side and center anchor points for spring attachment
- > Designed to be mounted flush against the wall

Dimensions: 55.5 cm x 180 cm x 7.5 cm. 80 cm (maximum width)



PED & PULL

ELN 500021

The Ped & Pull is the perfect tool to help those suffering from shoulder or back injuries by improving postural awareness. It develops core strength and balance. The Ped & Pull is ideal for small work areas.

Non-slip heart-shaped wooden base. Stainless steel post attachable to the wall.

INCLUDES

- > 2 medium intensity springs (green).
- > Horizontally regulable in 3 positions. Adapted to any people size.
- > 2 padded handles.
- > Anti-slip wood base.
- > 1 stainless steel pole with regulable height.

Base: 48x60 cm. Ancho: 57 cm.

Regulable height: 2,30 cm máx.



C
H
A
I
R
S

COMBO CHAIRS

Manufactured with high quality materials. They have been designed under the guidelines of the best Pilates professionals from around the world. Made of high quality wood. Perfect stability. Removable and adjustable handles to 127 cm, 119 cm, and 11 cm. all metal parts made of stainless steel or strong anodized aluminum.

FEATURES

- > Spring anchorage system on the rear bar in different positions.
- > Saddle springs: 2 medium-resistance (green), 2 high-resistance (red).
- > Feet with padding, can work separately or together.
- > With wheels for easy movement.
- > All models include elastic straps with handles for resistance exercises.
- > Different colors of upholstery.

Seat size: 61x35 cm.

Base size: 76x60 cm.

Base size with extension: 84x80 cm.

Total height: 127 cm.



ELITE COMBO CHAIR

ELN 700198

With innovative lower spring system for reverse resistance. Includes mini spring system, 2 medium and 2 strong, for resistance exercises.

Weight: 39 kg.



COMBO CHAIR STEEL BASE

ELN 700200

Light and resistant chair.

Black steel base.

Weight: 36 kg.



COMBO CHAIR WOOD BASE

ELN 700202

Made with high-quality materials to ensure its strength and durability, the Wooden Combo Chair Base is a perfect option to add to your Pilates workouts. Its main features include springs of different resistances with height adjustments and removable, adjustable handles at 3 different heights.

Peso: 37 kg.





elina
PILATES



ALMA CHAIR

ELN 400407

Alma Pilates Chair. Beauty and functionality in perfect harmony

The Alma Chair redefines training with a modern and attractive design that stands out in any setting, without compromising the strength and versatility required for professional Pilates practice.

Designed to offer stability, fluidity, and control in every movement, the Alma Chair is the perfect choice for those seeking quality, style, and performance in a single piece.

FEATURES

- > High-strength wood, lightweight and compact.
- > High-quality stainless steel metal parts.
- > Spring anchoring system on the rear bar with multiple positions.
- > Padded pedals with non-slip coating, can be used separately or together.
- > High-quality upholstery, resistant to intense and continuous use, with integrated system.
- > Wooden stick insertable into the pedals.
- > Handles with elastic straps for resistance exercises.

Dimensions: 84x68x57cm



INCLUDES

- > Chair structure.
- > Padded pedals.
- > 1 set of padded handles with elastic straps.
- > Chair springs: 2 springs.
- > Wooden stick to join the pedals.





COMBINATION WUNDA | ELECTRIC CHAIR

ELN 400206

The Combination Wunda/Electric Chair is designed to offer the most complete Pilates training possible. The base is made of maple wood that provides great stability to any user. The resistance of the pedal is regulated by two springs that generate a tension adapted to the preferences of each user.

FEATURES

- > The central structure incorporates two steel bars with comfortable grips on the sides to help the user maintain balance and perform the exercises with the utmost precision without straining the joints.
- > The seat is upholstered in durable leather and padded with high density EVA foam.

The Classic Combo Chair with backrest includes:

- > Maple wood frame.
- > 2 springs.
- > 3 hook positions per spring.
- > Galvanized steel tubing with aluminum handles.

Length: 83.82 cm
Width: 63.5 cm





BABY CHAIR

ELN 400306

With the Pilates Baby Chair you can strengthen your back and accelerate the recovery process of injuries through more than 60 types of exercises. Can be performed similar exercises to those we do on other Pilates equipment, making it ideal for learning processes. An ideal tool for Pilates teachers.

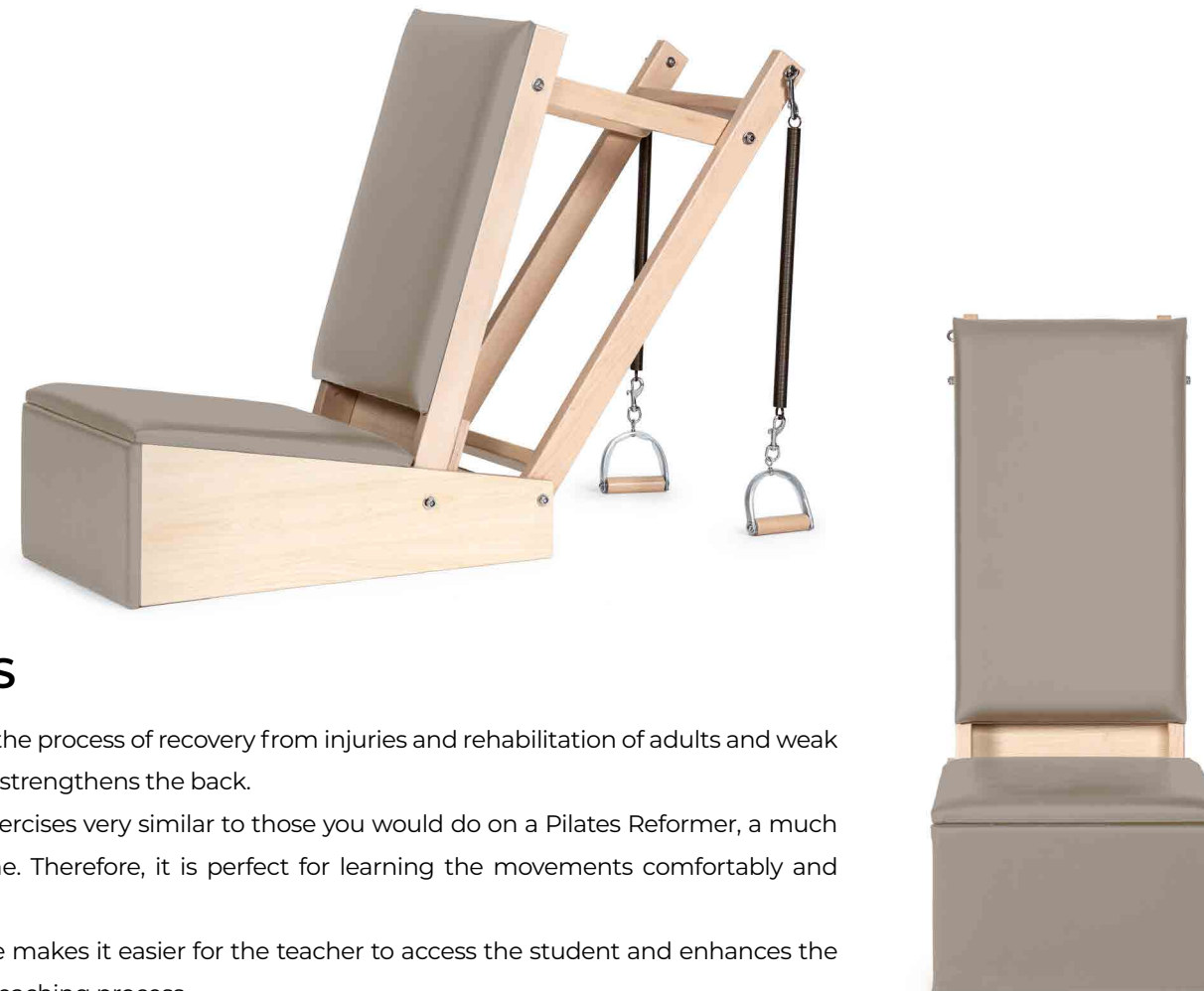

INCLUDES

- > It accelerates the process of recovery from injuries and rehabilitation of adults and weak people. It also strengthens the back.
- > You can do exercises very similar to those you would do on a Pilates Reformer, a much larger machine. Therefore, it is perfect for learning the movements comfortably and safely.
- > Its smaller size makes it easier for the teacher to access the student and enhances the learning and teaching process.
- > Thanks to the structure of the Baby Chair you can perform more than 60 different Pilates exercises.
- > The Baby Chair consists of a base on which you can sit or kneel and two springs to place the arms connected to a movable backrest.

CLASSIC WUNDA CHAIR

ELN 400106

Classic Wunda Chair designed in solid maple wood of high quality and resistance. The resistance of the pedal is regulated by two springs that generate a tension adapted to the preferences of each user. Maximum comfort oriented to generate the least possible muscle tension.

INCLUDES

- > Maple wood frame.
- > 2 springs.
- > 3 spring hook positions.
- > Different upholstery colors available.

Length: 78,74 cm.

Width: 53,34 cm.

Height: 58,42 cm.



FOLDING MAT WITH HANDLES

ELN 300056

Folding Classic Mat with handles with very comfortable and pleasant to the touch padding of great durability. It adapts to the structure of your body both in static and in movement. Allows muscle toning, increase flexibility and rehabilitation of injuries through specific exercises aimed at continuous evolution.

FEATURES

- > The two wooden bars of pleasant touch and great resistance allow exercises that relieve joint tension in the shoulders
- > providing the necessary stability to perform the exercises.
- > It is very light and, thanks to its two wooden bars, it is very easy to move wherever you need it.
- > And because it is foldable, you can store it in the space you have at home or in your studio.
- > Perfect for both beginners and advanced users.

INCLUDES

- > Two detachable wooden handles.
- > Two moon boxes of the same thickness to complete its function.
- > It has two handles on the sides to transport it comfortably once folded and reduced in size.
- > Different upholstery colors available.

Unfolded dimensions:

Length: 200 cm.

Width: 60 cm.

Height: 5.5 cm.

Folded dimensions:

Length: 100 cm.

Width: 60 cm.

Height: 11 cm.





LADDER BARRELLS

LADDER BARRELL ELITE WITH WOODEN BASE

ELN 700204

Adjustable length: 100-120cm. **Total size:** 95x120cm.

Barrel size: 55x88cm. Weight 31 kg. Different colors of upholstery.



LADDER BARRELL ELITE WITH STEEL BASE

ELN 700206

Adjustable length: 100-120cm. **Total size:** 95x120cm.

Barrel size: 55x88cm. Weight 31 kg. Different colors of upholstery.



WOOD BASE LADDER BARRELL

ELN 700208

Adjustable length: 100-120cm. **Total size:** 95x120cm.

Barrel size: 55x88cm. Weight 31 kg. Different colors of upholstery.



STEEL BASE LADDER BARRELL

ELN 700210

Adjustable length: 100-120cm. **Total size:** 95x120cm.

Barrel size: 55x88cm. Weight 31 kg. Different colors of upholstery.



ARCS

HOLLOW ARC

ELN 700220

Size: 54 x 57 x 18 cm.

Weight: 3,5 kg. Different colors of upholstery.



ARC PILATES

ELN 700218

Size: 48,5 x 43,5 x 18 cm.

Weight: 4 kg. Different colors of upholstery.



SPINE CORRECTOR

ELN 700216

Dimensions: 79 x 45 x 32 cm.

Weight: 11,5 kg. Different colors of upholstery.



ELITE SPINE CORRECTOR

ELN 700214

Size: 74 x 46,5 x 33 cm

Weight: 9,5 Kg.



ELITE SPINE CORRECTOR 3 EN 1

ELN 700212

Barrell length: 74 cm - Barrell width 48 cm.

Barrell height: 24-28-32 cm. Weight: 24 kg. Different colors of upholstery.



SPINE SUPPORTER

ELN 700222

With handles. Special for pregnant women.

Size: 80 x 41 x 42 cm. Weight: 8 kg. Different colors of upholstery.



ACCESORIES

BIG BOX FOR PILATES

ELN 700226

Size: 77 x 47,5 x 28cm



BOX MEDIUM FOR PILATES

ELN 700228

Size: 71 x 40 x 28 cm



TRIANGLE

ELN 700224

Size: 80 x 41 x 35 cm. Weight: 7 kg.

Different colors of upholstery.

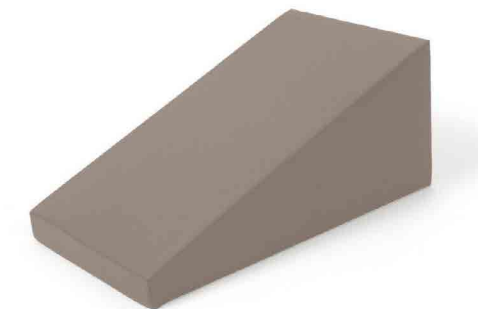

POSTURAL WEDGE

ELN 460006

The Elina Pilates Postural Wedge is an accessory designed to provide support and comfort during Pilates practice.

Size: 7 x 58,5 x 81,5 cm.

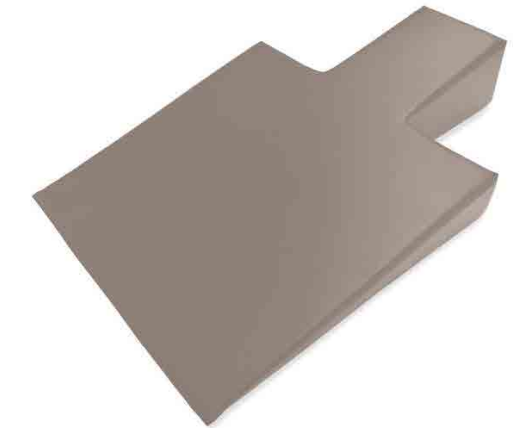

ARKUS PILATES

ELN 500006

Logra mayor libertad de movimientos adaptándose al contorno del cuerpo. Más versátil que la barra recta tradicional. Puede conectarse a todo tipo de reformer. Fabricado en madera laminada en diferentes tonalidades. 4 gan- chos para muelles.

Medidas: 102 x 24,5 cm. **Diámetro:** 3 cm



CLASSIC ACCESORIES

AIRPLANE BOARD

ELN 500105

Perform the Airplane Pilates exercise comfortably, safely and in a controlled manner on your Cadillac thanks to the Airplane Board. Its solid wood base provides the support and confidence you need to perform the most difficult Pilates exercises. Suitable for all types of users.

By attaching the Airplane Board to your Cadillac, you will be able to perform the Pilates Airplane exercise in a more comfortable, controlled and safe way. You'll literally be standing up in the air.

The solid wood base provides support and confidence during your Pilates workout, even the most difficult exercises..



BEAN BAG ROLL-UP DEVICE

ELN 500106

Strengthen the mobility of your arms, wrists and forearms by exercising with the Bean Bag. Place the bar at shoulder height and unroll and roll up the rope. Ideal for tennis elbow healing therapies.

The Bean Bag exercise consists of placing the wooden bar at shoulder height and rolling and unrolling up the rope around the bar. You must maintain a very specific position so that the fingers, hands, wrists and forearms are strengthened during the exercise.



BREATH A CIZER

ELN 500104

The Pilates breathing exerciser is a device with a windmill-type wheel. Blowing through the straw moves the wheel and improves diaphragmatic breathing.



CLASSIC ACCESORIES

FOOT CORRECTOR

ELN 500100

Correct and strengthen your feet, improve your balance and helps you to walk better with the Foot Corrector. It adapts to all types of feet and its material is soft and resistant, avoiding pinching or damage.



NECK STRETCHER

ELN 500101

With the Neck Stretcher you can strengthen your neck muscles, facial muscles and reinforce the stability of your spine. Regular use can lengthen the neck joint. To use it, you need a Pilates Cadillac, a Wall Unit or a Guillotine Tower for Pilates.

The Neck Stretcher has a strap that is tied around the forehead and back of the neck, a ring that attaches it to a machine that exerts resistance and two rubber straps that attach to a Cadillac, Wall Unit or Guillotine Tower. Once attached to your forehead, you must pull with your neck so that the machinery exerts resistance and you can exercise your neck muscles.

Of course, the correct use of the Neck Stretcher will not cause you any harm, but quite the opposite: it will strengthen your neck muscles, your facial muscles and reinforce the stability of your spine. Of course, you must do the exercises with care.



CLASSIC ACCESORIES

PUSH UP DEVICE

ELN 500103

Push-up device or structure to do push-ups for Pilates in a stable and safe way. Develops the nervous system through a wide range of movements.

It prioritizes the development and care of the nervous system and exercises the muscle groups in a uniform and balanced way. You can perform a wide range of motion in your push-up workouts, combining them and extending your sessions. Its main exercises define the body, they do not generate hypertrophy.

The push-up machine is very stable and safe, allowing all types of Pilates movements without interference. The very structure makes it easy to transport, as it has comfortable grips of great resistance and does not weigh excessively.



TOE EXERCISER

ELN 500102

Toe Exerciser or Pilates Toe Exerciser reinforces, corrects, strengthens and aligns the toes. It strengthens and flexes the musculature and increases the ability to do Pilates workouts correctly, since the exercises are always without shoes.

In most of the current Pilates machines, such as the Reformer, the feet assume a fundamental role in the correct execution of the exercises, since most of them are performed without shoes. It is therefore important to strengthen the toes with the Toe Exerciser.

The Toe Exerciser is very comfortable to use. Two soft straps are placed on the big toes of both feet, leaving the device between them. Once in this position, the feet are moved to the opposite sides, generating resistance in the straps and exercising the toes.

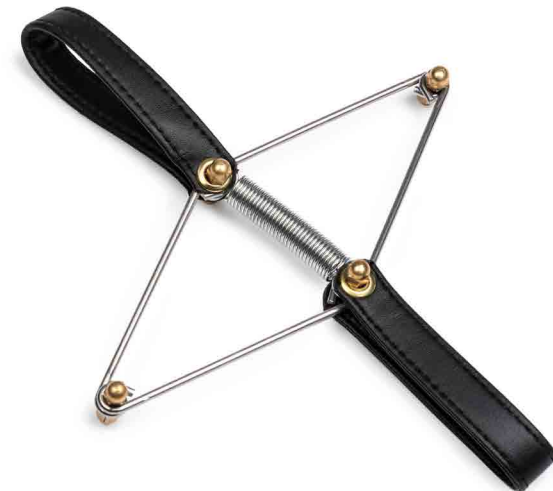

ACCESORIES

AB MAT

PA 55059700

Size: 37 x 30 x 6 cm



ROTATION DISC

ELN 500002

Very smooth and quiet turning. Anti-slip.

Diameter: 30,5 cm. **Height:** 4 cm.



MINI MAT NON-SLIP KNEE PROTECTOR

ELN 800038

Non-slip protector. Perfect for Yoga and Pilates.

Size: 35 x 20 x 0,9 cm.



MINI NON-SLIP PAD

ELN 800203

Size: 55,5 X 11cm



ERGONOMIC PAD

ELN 800104

Sizes: 28 x 18 x 7 cm



SLIDING PLATFORM

ELN 700125

Glides on any surface. Wooden structure, padded and with wheels.



ACCESORIES

PILATES MACHINE TOWELL

ELN 80010003

Special towel for Pilates machine users. With a non-slip base for an optimal handle and slipping prevention on the mat, it is made of maximum resistance microfiber. Excellent sweat absorption and maximum hygiene.

Available colours:

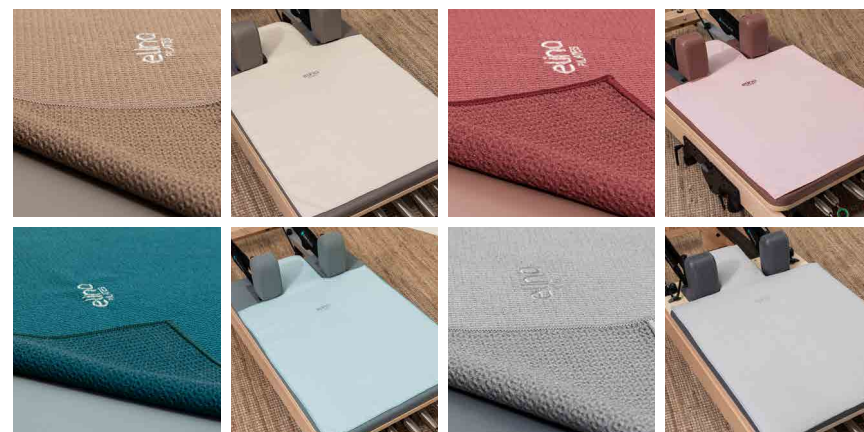

LONG TOWELL

ELN 800110

Long towel for Reformer made of microfiber of maximum resistance with non-slip base. Maximum sweat absorption.

Sizes: 200 x 59 cm



SUSPENSION BELT

ELN 800053

Resistant and adjustable to all lengths. Includes grab carabiners. Adapted to suspension exercises on any platform. Originally designed for Elina Pilates ONNE Wall Board.



ADJUSTABLE FOOT STRAP

ELN 800024

Strap to hold the foot in the Reformer. It has two swivel carabiners. Short 52 to 70 cm. Long 70 to 110 cm.



BELLY STRAP

ELN 800025

Maximum length 230 cm. Minimum length 195 cm.



ACCESORIES

REFORMER DOUBLE HANDLES

ELN 800015

Double cotton handles. Padded. Maximum resistance.

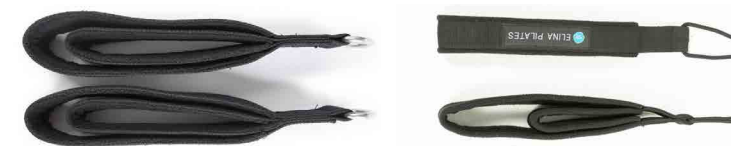

REFORMER SIMPLE HANDLES

ELN 800014

Cotton simple handles. Padded. Maximum Resistance.



CADILLAC-REFORMER FUZZIES

ELN 800069

The "Fuzzies" for Cadillac in Pilates are plush pads that are placed at the end of the horizontal bars of the Cadillac to protect the user's hands and feet during exercises. Their soft texture provides comfort and a better grip during Pilates exercises.



REFORMER PADDED HANDLES

ELN 800013

Padded hand handles.



ANKLE LOOPS

ELN 500020

Designed to be fastened more easily than a conventional strap.

Perfect for people with difficulties or less ability to perform this kind of exercises.



REFORMER ROPES

ELN 800022

Reformer ropes. Size 2,7m. Made of super resistant synthetic material.



SUPPORT ROPE FOR PUSH BAR – REFORMER/CADILLAC

ELN 800023

Optimize the performance and safety of your machine with this fastening rope specifically designed for the Push Bar of Reformer systems with tower and Cadillac.

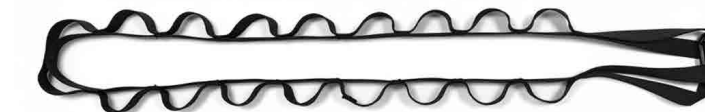

SMALL EQUIPMENT



SMALL EQUIPMENT

PILATES SPRING HANGER

ELN 800050

Wall hanger for 12 springs. Two extra hooks at each end for other types of accessories, such as handles.



SPRING FOR PILATES MACHINE

Spring specially made for our Pilates machines. Composed of an innovative anti-oxidant and ultra-resistant steel, especially endowed with greater resilience and durability than a conventional spring.

Ensures an optimum tension quality.



BED SPRING

ELN 800028

Light resistance - Yellow

ELN 800027

Medium resistance - Green

ELN 800026

Strong resistance - Red

TOWER SPRING

ELN 800009

Short light resistance - Yellow

ELN 800010

Short medium resistance - Green

ELN 800011

Long light resistance - Yellow

ELN 800012

Long medium resistance - Green

SMALL EQUIPMENT

MAGNETIC WRIST & ANKLE STRAP

ELN90000000

Adjustable 0.5 kg wrist and ankle straps with a magnetic closure, designed for maximum comfort and quality, providing extra resistance for your Pilates, yoga, rehabilitation, contact sports, or cardio workouts.

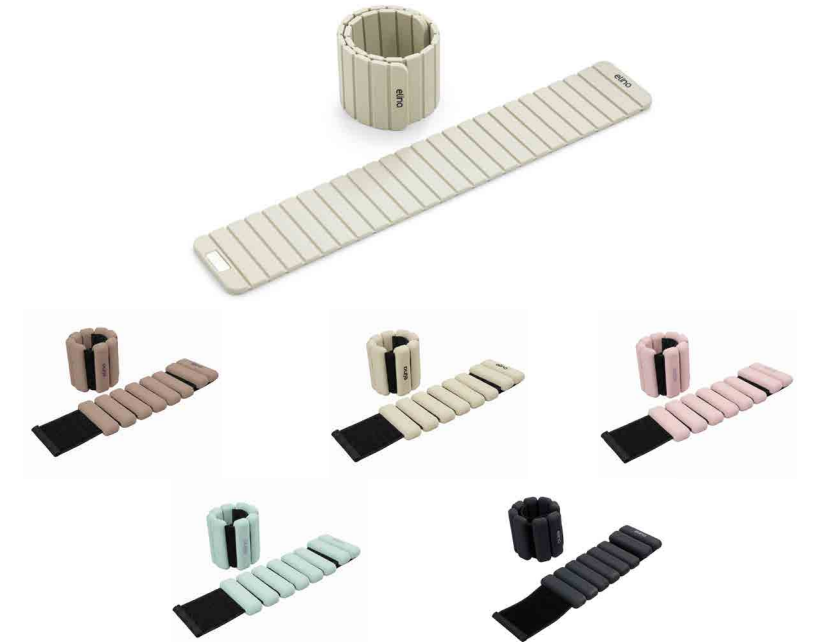

WEIGHTED WRIST STRAP

ELN 90000004

Adjustable 0.5 kg and 1 kg wrist straps, designed for maximum comfort and quality, providing extra resistance for your Pilates, yoga, rehabilitation, contact sports, or cardio workouts.



D-DUMBBELL

ELN 90000500

It allows for quick changes during your workout without stopping, minimizing distractions and enabling greater efficiency, speed, and results in your exercises.

1 KG NEOPRENE DUMBBELLS

ELN 61004104

Its neoprene coating provides a comfortable, non-slip grip.

Available colors:



NEOPRENE DUMBBELLS - 1 KG TO 5 KG

ELN 61004100

Neoprene dumbbells from 1 to 5 kg, featuring a comfortable, non-slip grip.

Available colors:



SMALL EQUIPMENT

FITNESS BALLS

PA 50005130

Balls made of Tecno Caucho, providing high abrasion resistance and maximum elasticity. Available in different sizes and colors.



Available colours:



FITBALL PILATES BALLS

ELN 50005503

Made from ultra-resistant and safe material, available in 55 cm and 65 cm options, it allows you to perform a wide variety of exercises: core strengthening, balance improvement, muscle toning, and stretching.

Ø 55 and 65 cm



Available colours:



PILATES BALLS SOFT PRO 20CM

ELN 50004003

Made from ultra-resistant and safe materials, the Elina Pilates Soft Pro Ball ensures safety and durability in every session. With this ball, you can perform a wide variety of Pilates exercises.



Available colours:



PILATES BALLS

ELN 500011

Balls made of resistant vinyl which makes them durable, light, soft to the touch and washable.

They are available in different sizes (20 and 22 cm) and colors.

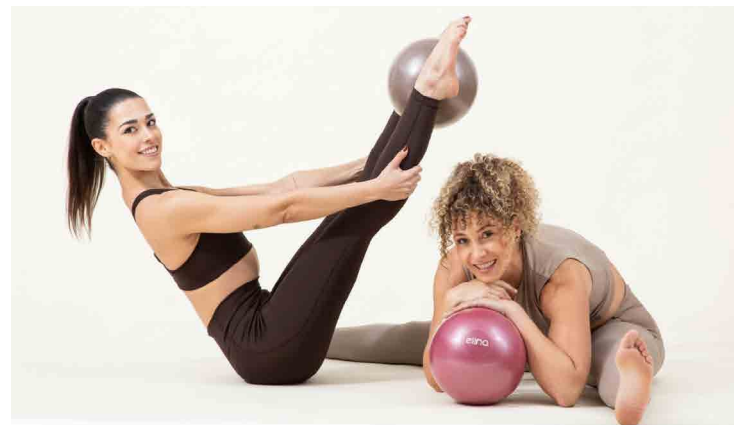

Available colours:



SMALL EQUIPMENT

OXYGEN BALLS

PA 61004800

Oxygen balls are perfect for Pilates. They fit perfectly in your hand. They increase the intensity of the exercise and help to exercise arms, shoulders and trunk. Available in 0,5kg and 1kg.



SPYKE BALL MASSAGE BALL

PA 52095200

Very useful massage ball for self-massage and postural education.

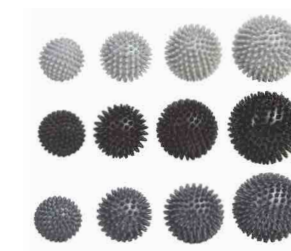

PILATES FOAM ROLLER

ELN 53052517

High-density, durable EVA foam roller.

90 cm x Ø 15 cm

Available colours:



ROLLERS

PA 53052514

Different materials and sizes.

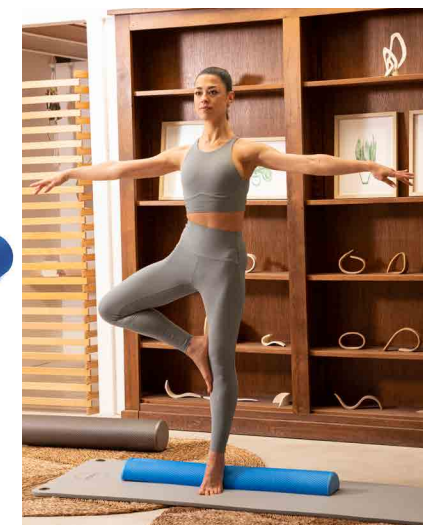

SMALL EQUIPMENT

PILATES PROFESSIONAL RING

ELN 61007903

Professional Pilates ring.

Great resistance.

Ø 38 cm, 500 grs.

Available colours:



RESISTANCE BANDS

ELN 90000100

Three levels of resistance.

Durable and comfortable material.

Ideal for all levels.

Available colours:



ELASTIC BANDS ROLL 25M.

PA 61007500

25 m roll. Width 15 cm. Different resistances.

High durability. Rubber.



INDIVIDUAL ELASTIC BANDS

PA 61007200

Individual latex elastic bands for arm and leg exercises. Different densities and hardness.

Size: 1.5 m long and 15 cm wide.

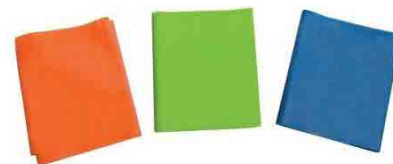

SMALL EQUIPMENT

PILATES MAT

Anti-bacterial and anti-slip protection.

Made of a new material of high resistance and high density, very pleasant.

Available in two sizes (180x58cm and 140x58cm) and different colors.

Colors:



MAT HANGER

PA 61006900

Steel hanger with adjustable brackets. Suitable for all types of mats with eyelets in different sizes. **Size:** 65 x 10 cm. With 2 supports with a diameter of 8 mm and a length of 25 cm..



DOUBLE SHELF FOR ADJUSTABLE MATS WITH WHEELS

PA 61001900

Mobile shelf for mats and accessories. It has wheels for easy transport. Suitable for all types of mats up to 180 cm long.



WALL BARS FOR MATS

PA 61001500

Wall bars for mats (set of 2).

Size: Support 10 x 5 cm. Bar 25 cm x 12 mm diameter.





SMALL EQUIPMENT

ACCESSORIES PACK

Ring, resistance bands, dumbbells, ball, foam roller, and matching mat for your Pilates workouts at home or in the gym.

Available colours:



PAC 500007



PAC 500011



PAC 500009



PAC 500001

SMALL EQUIPMENT

TRAINING CORD

TC 60994199

Work both the lower and upper body, with a wide variety of exercises to target the muscle groups that interest you the most. For both individual and group use in a studio. It can be incorporated into both Pilates, rehabilitation, functional training or fitness programs.



SPINE ALIGNER FITS

ELN 45003000

Improve your postural well-being with the innovative Spine Aligner Fits, an essential tool for any Pilates routine and postural well-being.



PILATES POLE

PA 61007000

Length 1.20 m, Ø 30 mm
Maple wood.



AIR STEP PRO

PA 55058500

The new Air Step Pro is a very resistant and functional product, which allows the performance of multiple exercises in which stability and balance are involved. Available with and without handles and in different colors: black, grey and blue.



YOGA & PILATES GONDOLA POLE

ELN 800119

Length 1.50 m, Ø 31 mm
Maple wood.



SMALL EQUIPMENT

YOGA HAMMOCK 250*145 CM

ELN 61009312

Made of comfortable, high quality material, which provides a high level of safety during suspension exercises.

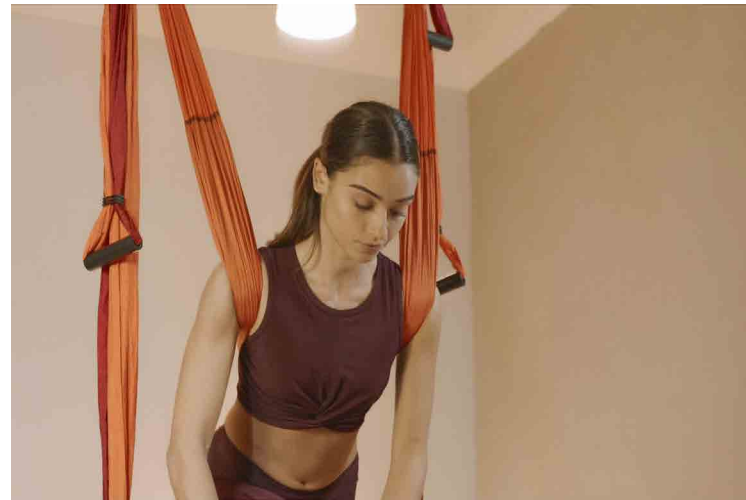

AERIAL YOGA 500*280 CM

ELN 61008012

It improves flexibility and helps to enhance deep breathing.

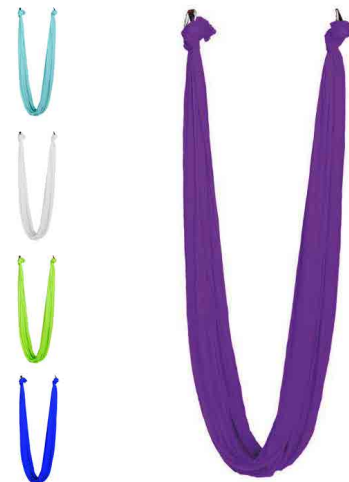

SMALL EQUIPMENT



WALL SUPPORT FITNESS BALLS

PA 61001605

High quality steel wall support and resistance for fitness balls.

Place several balls at the same time in a stable and comfortable way and save space.

Anchoring to the wall in an easy, stable and safe way.

Size: 224 x 17 x 7 cm.



BASES FOR STACKING OF FITNESS BALLS

PA 61001600

Allows stacking of any size of fitness balls.

Set of 3 units.



FITNESS BALL RACK

PA 61001601

For 10 Units

Metal Floor Stand



COMPARISON CHART

	Total length cm.	Total width cm.	Bed height cm.	Weight Kg.	Frame	Springs	Rope system	Carriage suspension	Springbar adjustments	Foot bar	Foot bar horizontal positions	Box and jump board	Wheels	Vertical storage	Stackable	Shoulders	Tower + Mat	Tower height	Springs tower	Frame warranty
Master Instructor	242	83	40	81	Maple	2S 2M 2L	Retractable	√	2	Quick Release 7 pos.	20	Included	√	-	√	Removable-Adjustable	√	203	2M-long 2L-long 2M-short 2L-short	10 years
Master Instructor Physio	242	83	60	88	Maple	2S 2M 2L	Retractable	√	2	Quick Release 7 pos.	20	Included	-	-	√	Removable-Adjustable	√	223	2M-long 2L-long 2M-short 2L-short	10 years
Mentor	259	75	40	81	Aluminium	2S 2M 2L	Retractable	√	2	Quick Release 7 pos.	22	Included	√	√	-	Removable-Adjustable	√	190	2M-long 2L-long 2M-short 2L-short	10 years
Elite Advanced	241	77	35	85	Maple	2S 2M 2L	Retractable	-	2	Quick Release 7 pos		Included	-	-	√	Removable-Adjustable	√	202	2M-largo 2L-largo 2M-corto 2L-corto	10 years
Elite	241	77	35	85	Maple	2S 2M 2L	Standard	-	4	Quick Release 7 pos.	1	Included	√	-	√	Removable-Adjustable	√	202	2M-long 2L-long 2M-short 2L-short	10 years
Nubium	249	78	36	63	Aluminium	2S 2M 1L	Standard	-	2	Handle 7 pos.	1	Included	√	√	-	Removable-Adjustable	√	203	2M-long 2L-long 2M-short 2L-short	5 years
Lignum	242	68	36	63	Maple	2S 2M 1L	Standard	-	3	Quick Release 6 pos.	1	Included	√	√	-	Removable-Adjustable	√	194	2M-long 2L-long 2M-short 2L-short	5 years
Wood Reformer	237	69	33	70	Maple	2S 2M 1L	Standard	-	4	Standard 4 pos.	1	Included	√	-	-	Removable	√	202	2M-long 2L-long 2M-short 2L-short	10 years
Wood Reformer Physio	237	69	48	80	Maple	2S 2M 1L	Standard	-	4	Standard 4 pos.	1	Included	√	-	√	Removable	√	217	2M-long 2L-long 2M-short 2L-short	10 years
The Club Reformer	236	68,5	35	85	Maple	2S 2M 1L	Retractable	-	2	Standard 4 pos	1	Included	-	-	-	Removable-Adjustable	√	197,5	2M-long 2L-long 2M-short 2L-short	10 years
Twin Reformer	245	90	40	81,5	Maple	4S 4M 4L	Standard	-	-	Quick Release 7 pos.	28	Included	√	-	-	Removable-Adjustable	√	196	2M-long 2L-long 2M-short 2L-short	10 years
Reformer HL1	240	67	22	62	Aluminium	2S 2M 1L	Standard	-	4	Quick Release 6 pos.	1	Included	√	√	√	Removable	√	179	2M-long 2L-long 2M-short 2L-short	10 years
Reformer HL2	240	67	27	65	Aluminium	2S 2M 1L	Standard	-	4	Quick Release 6 pos.	1	Included	√	√	√	Removable	√	190	2M-long 2L-long 2M-short 2L-short	10 years
Reformer HL3	240	67	42	65	Aluminium	2S 2M 1L	Standard	-	4	Quick Release 6 pos.	1	Included	√	√	√	Removable	√	205	2M-long 2L-long 2M-short 2L-short	10 years
Reformer HL4	240	67	62	70	Aluminium	2S 2M 1L	Standard	-	4	Quick Release 6 pos.	1	Included	√	√	√	Removable	√	225	2M-long 2L-long 2M-short 2L-short	10 years
Vertical for home	235	61	36	62,5	Maple	2S 2M 1L	Retractable	√	-	Standard 6 pos.	1	Optional	√	√	-	Removable-Adjustable	-	-	-	5 years
Foldable for home	235	61	36	72	Maple	2S 2M 1L	Retractable	√	-	Standard 6 pos.	1	Optional	√	√	-	Removable-Adjustable	-	-	-	5 years
Domo	238	58	16	44	Aluminium	2S 2M 1L	Standard	-	1	Handle 3 pos.	1	Optional	√	√	-	Removable	-	-	-	3 years
Classic Aluminium 86"	225	66	35	50	Aluminium	4	Standard	-	3	Classic 2 pos.	1	Included	-	-	-	Removable	√	185	2M-long 2L-long 2M-short 2L-short	10 years
Reformer Clásico Madera Natural	225	66	35	50	Maple	4	Standard	-	3	Classic 2 pos.	1	Included	-	-	-	Removable	√	183,5	2M-long 2L-long 2M-short 2L-short	10 years
Reformer Clásico Madera Oscura	225	66	35	50	Walnut	4	Standard	-	3	Classic 2 pos.	1	Included	-	-	-	Removable	√	183,5	2M-long 2L-long 2M-short 2L-short	10 years

SPRINGS RESISTANCE
S = STRONG - RED
M = MEDIUM - GREEN
L = LIGHT - YELLOW

Our Reformers are available in various standard upholstery colors and in over a hundred customizable upholstery colors of the customer's choice.

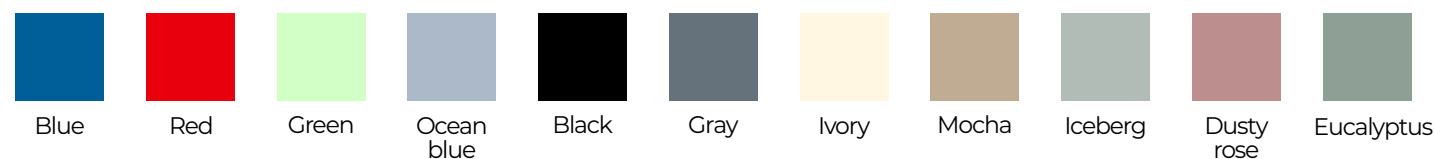

COMPARISON CHART

	Largo total cm.	Ancho máximo cm.	Alto de cama cm.	Peso Kg.	Estructura	Muelles	Sistema cuerdas	Amortiguación carro	Posiciones barra Muelles	Barra de pies	Ajuste horizontal barra pies	Tabla de salto y box	Ruedas transporte	Posición vertical	Apilable	Hombreras	Opción torre y mat	Altura con torre cm	Muelles torre	Garantía estructura			
RClassic Natural Wood Cadillac Reformer	225	66	35	120	Maple	4	Standard	-	3	Classic 2 pos.	1	Included	-	-	-	Removable	√	183,5	2M-long 2L-long	2M-short 2L-short	10 years		
Classic Walnut Wood Cadillac Reformer	225	66	35	120	Nogal	4	Standard	-	3	Classic 2 pos.	1	Included	-	-	-	Removable	√	183,5	2M-long 2L-long	2M-short 2L-short	10 years		
Wood Cadillac	251	78	58	108	Maple	2S	2M-long 2L-long	2M-short 2L-short	-	-	-	-	-	-	-	-	-	215	2M-long 2L-long	2M-short 2L-short	10 years		
Cadillac - Reformer	240	78	56	175	Maple	2S	2M-long 2L-long	2M-short 2L-short	Standard	-	4	Standard 4 pos.	1	Included	√	-	-	Removable	-	215	2M-long 2L-long	2M-short 2L-short	10 years
Cadillac - Reformer Elite	248	88	56	185	Maple	2S	2M-long 2L-long	2M-short 2L-short	Standard	-	4	Quick Release 7 pos.	1	Included	√	-	-	Removable-Adjustable	-	220	2M-long 2L-long	2M-short 2L-short	10 years
Classic Cadillac	220	68	63	120	Aluminium	2S	2M-long 2L-long	2M-short 2L-short	-	-	-	-	-	-	-	-	-	210	2M-long 2L-long	2M-short 2L-short	10 years		
Corextreme	327,7	66	45,3	180	Aluminium	8	-	-	-	-	-	-	-	-	-	-	-	-	-	-	10 years		

SPRINGS RESISTANCE
S = STRONG - RED
M = MEDIUM - GREEN
L = LIGHT - YELLOW

Our Reformers are available in various standard upholstery colors and in over a hundred customizable upholstery colors of the customer's choice.

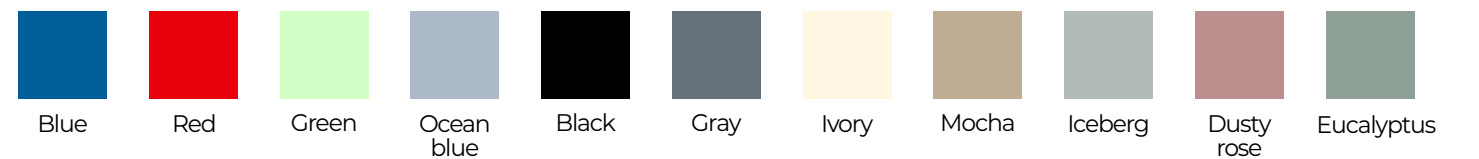



elinapilates.com

